

Official Scorer's Manual

12th Edition 2019



Softball New Zealand (SNZ) is the governing body of softball in New Zealand.

SNZ is affiliated to the World Baseball and Softball Commission (WBSC)

www.wbsc.org



Contents

1.	Introduction	1	3.29.	Extent of An Error	24
1.1.	Types of Scorer.....	1	3.30.	More Than One Error.....	24
1.2.	Qualities of a Scorer.....	1	3.31.	Out-Errors and Advance-Errors	25
1.3.	Duties of a Scorer	2	3.32.	Assists with Errors	26
1.4.	Scorers Equipment.....	2	3.33.	Fielder's Choice (FC).....	26
2.	The Scoresheet	3	3.34.	Fielder's Choice on a Batter ...	26
2.1.	Scoresheet Parts	3	3.35.	Fielder's Choice on a Runner .	27
2.2.	Top/Bottom	4	3.36.	Second Phase Play	27
2.3.	Team Line-ups	4	3.37.	Double and Triple Plays.....	27
2.4.	Team Sheets.....	5	4.	Multi-Symbol Plays	28
2.5.	The Game	5	4.1.	Error on a Foul Fly	28
2.6.	Game Analysis.....	5	4.2.	Error on Sacrifice Fly	28
2.7.	Game Summary.....	6	4.3.	Stolen Base Attempts	28
2.8.	Game Start Time.....	6	4.4.	Double Steal	29
2.9.	The Box.....	6	4.5.	Sacrifice Bunt, Error, Fielder's Choice.....	29
2.10.	Closing off the Innings	6	4.6.	Tie Breaker	30
2.11.	Innings Totals.....	7	4.7.	Fast Pitch.....	30
2.12.	Innings Fielding.....	7	5.	Substitutes and Position Changes.....	31
2.13.	Innings Overflow	8	5.1.	Substitute.....	31
2.14.	Scoresheet Overflow.....	8	5.2.	Change Indicator Lines.....	31
3.	Use of Symbols	9	5.3.	Blood Bin	34
3.1.	Official Symbols	9	6.	Analysis	36
3.2.	Balls and Strikes Count.....	10	6.1.	Batting and Running Summary	36
3.3.	Safe Hits (-, +, ++, +++)	10	6.2.	Analysis Examples.....	37
3.4.	Hit Location	11	6.3.	Runs Batted In	37
3.5.	Extra Base Advance	11	6.4.	Reach Base	38
3.6.	Runners Advance	11	6.5.	Splitting Batters.....	38
3.7.	Automatic Hit (A).....	12	6.6.	Pressure Batting	38
3.8.	Length of Hit.....	12	6.7.	Fielding Summary	39
3.9.	Slap Hit (S).....	12	6.8.	Pitching and Catching Summary	40
3.10.	Bunt.....	13	6.9.	Earned Runs.....	41
3.11.	Sacrifice	13	6.10.	Reconstruction Examples	43
3.12.	Batted Ball Caught.....	14	6.11.	Reconstruction Examples	44
3.13.	Batting Out of Order.....	15	6.12.	Game Summary.....	45
3.14.	Illegal Batting (IG)	16	6.13.	Proving the Box Score	46
3.15.	Strike Out (K)	16	6.14.	Tie Breaker	47
3.16.	Walk (BB).....	17	6.15.	Fast Pitch.....	47
3.17.	Intentional Walk (IBB)	17	6.16.	Cross Checks	47
3.18.	Ball 4 on WP or PB	17	6.17.	Tied Team Score	48
3.19.	Catchers Error (BBE2).....	17	7.	Scorers and Umpires	49
3.20.	Hit by Pitch (HP)	17	7.1.	Official Scorer - Duties.....	49
3.21.	Battery Errors.....	18	7.2.	Tied Team Formula	49
3.22.	Base running.....	18	7.3.	Protests.....	50
3.23.	Interference.....	21	7.4.	Umpires Decisions.....	50
3.24.	Obstruction.....	22	7.5.	Runs Scored	50
3.25.	Errors (E)	22			
3.26.	Scorer's Judgement.....	22			
3.27.	Scoring an Error.....	23			
3.28.	Reverse Error.....	23			

8.	Statistics.....	51
8.1.	Types of Statistician.....	51
8.2.	What Statistics are Required...	51
8.3.	Preparation of Statistics.....	51
8.4.	Expressing Averages	52
8.5.	Common Averages	52
8.6.	Tournament Cut-offs	53
9.	Case Studies.....	55
9.1.	Complicated Examples	55
9.2.	Batting Out of Order.....	57
9.3.	The Designated Player	58
9.4.	Reach Base	59
9.5.	Reconstruction Practice examples.....	62
9.6.	Statistical Averages: Batting, Reach and Pressure	63
10.	Index.....	65

Edition	Date	Prepared by
1 st	February 1974	Jean McLeay – Scorer’s Interpretation Panel
2 nd	February 1977	John Joyce – NZSA Chief Scorer
3 rd	December 1980	Ian Patterson – NZSA Chief Scorer
4 th	June 1984	Jean Humphreys – NZSA Chief Scorer
5 th	June 1986	Jean Humphreys – NZSA Chief Scorer
6 th	July 1987	Jean Humphreys – NZSA Chief Scorer
7 th	July 1989	Scorer’s Interpretation Panel: Esme Hamilton, Wanda Eadie, Russell Moffat
8 th	July 1994	Scorer’s Interpretation Panel: Wanda Eadie, Leonie Johnson, Raewyn Humphreys, Kamala McLeod, Russell Moffat, Ruth Dare
9 th	October 2000	Scorer’s Interpretation Panel: Russell Moffat, Dale Tamehana, Raewyn Humphreys, Joanne Herrick,
10 th	December 2008	Russell Moffat, Sandy Wallace
11 th	December 2017	Lil Natana, Elaine Karsten, Ian Ditford, Marie Byrne Lynnette Leathart
12 th	March 2019	To incorporate 2018 - 2021 Official Rules of Softball references

1. Introduction

Welcome to the Softball New Zealand Scorer's Manual. This manual outlines the standard scoring practices used in New Zealand.

For the sake of clarity and conciseness throughout the manual "he" is often used to refer to a player or an umpire. We realise there are male and female players and umpires – no offence is intended.

1.1. Types of Scorer

There are different types of scorer, each with quite different functions:

- **Official Scorer** - appointed by the association organising the game or tournament (on a similar basis to umpires). Responsible directly to that association for providing an unbiased record of the game.
- **Team Scorer** - appointed by, and part of, the team. Generally responsible to the team coach for providing a similar record.
- **Statistician** - responsible for producing statistics. At official level a separate scorer is often appointed as full-time statistician. While all scorers produce statistics on each game or for a team, the statisticians' role is to combine these statistics for all teams in a league or tournament.
- **Chief Scorer** - responsible for administration of scoring at a tournament, appointing scorers to games, running exams, resolving issues in conjunction with the tournament organiser.
At a local association level, a chief scorer can also be responsible for scoring in an association.

All of these scorers are responsible for producing true and meaningful results and statistics for the game, season, tournament, etc.



TIP: More info in Section 7 (Scorers and Umpires) and Section 8 (Statistics).

1.2. Qualities of a Scorer

To be a good scorer you need:

- *Sound knowledge* of scoring rules and their application, also a good knowledge of the playing rules, and of umpires' signals.
- *Understanding of statistics*, both in their production and their interpretation.
- *Good judgement and impartiality* for hit/error decisions etc. It is important to be consistent, both within your own decisions, and with the accepted New Zealand (and International) standards. Ultimately this consistency of judgement can be learned only by mixing with good qualified scorers – not from any book.
- *Concentration* during fast or complicated plays, and over the whole game in sometimes difficult conditions.
- Accuracy, neatness and speed.
- Common sense and logic.

1.3. Duties of a Scorer

The duties of a scorer include:

- Writing up the team line-up sheet if there is one (refer para 2.4).
- Exchanging line-ups with the opposition scorer (team scorer).
- Scoring the game in accordance with the rules and the practices outlined in this manual.
- Providing information to the umpire (official scorer) or coach (team scorer) during the game.
- Ensuring that the players in the game at any time are the correct players as listed on the official line-up sheet, or scoresheet at the beginning of the game (refer para 3.13).
- Providing the game results to the tournament organiser (official scorer).
- Analysing the game.

1.4. Scorers Equipment

You also need the following equipment:

- Scoresheet – plus a spare in case game lasts more than nine innings.
- SNZ Rule Book – all scorers should keep the latest rule book.
- Backing board and/or table – this should be at least as big as the complete scoresheet.
- Pens/pencils – while beginners may prefer pencil, blue or black pen make a scoresheet far easier to read. Runs *must* be filled in with **RED**. For a Designated Runner **GREEN** is used. *Please do not use highlighters or erasable pens.*
- Corrections – a rubber or correcting fluid, cross-outs are not recommended.
- Weather-proofing – firstly for the scoresheet: a clear plastic bag or sheet in case of rain, and clips or rubber bands in case of wind. Also – sun hat, sunscreen, glasses and warm weather-proof clothing and umbrella. A game may last for hours – as scorer you must remain there regardless.
- Timepiece – to record the time of the game.
- Seating – the more comfortable the better (but don't go to sleep).



Check out the New Zealand Softball Scorers Association webpages for information on things such as, uniforms, tournament application forms, the latest rules, development pathways, etc.

www.softball.org.nz/GET+INVOLVED/SNZ+Scorers.html



2. The Scoresheet

There are two halves to the scoresheet-each half show what happens while one team is batting (and the other team fielding). The following diagram shows an example of one half of the scoresheet. Both sides are identical apart from the bottom right square one side is used to record the start and finish time as per sample the other side you record the officials (refer para 6.12)

2.1. Scoresheet Parts

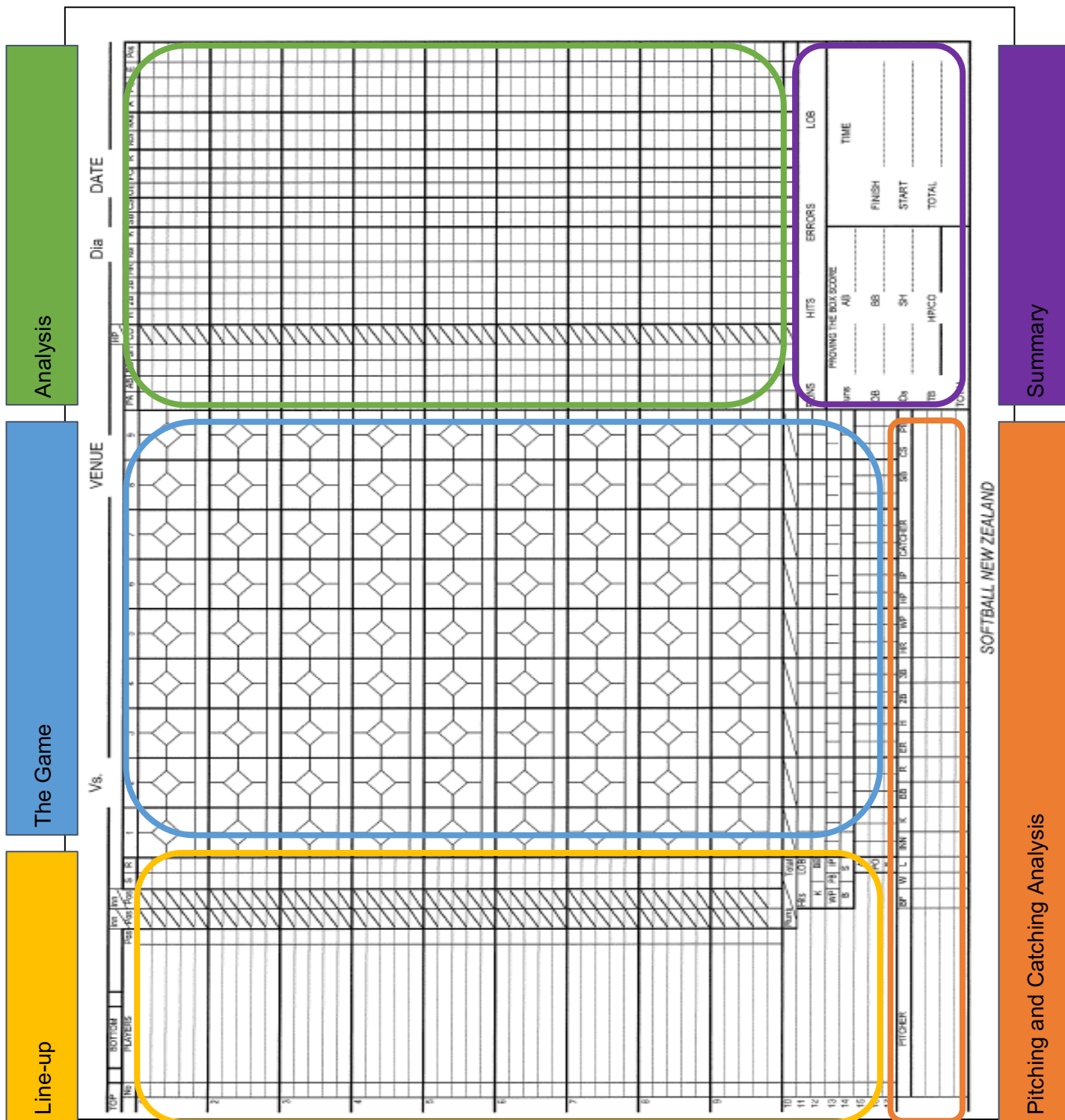

2.2. Top/Bottom

TOP		BOTTOM			Inn	Inn
No	PLAYERS			Pos	Pos	Pos

Before the Game begins teams will toss to determine who will bat or field first.

Colour in the 'Top' for the team that bats first, and 'Bottom' for the team that fields first preferably in **RED**. During the game this helps when recording substitutes and answering enquiries about the innings.

Make sure you write the team names and date on both sides of the scoresheet. This is important because scoresheets are often photocopied onto separate A4 sheets.

2.3. Team Line-ups

a. **Batter's Numbers:** These are pre-printed 1-9. Each number refers to the position within the batting order, so will apply to a different player after a substitution has been made. These numbers are used regularly throughout the scoring of a game.

TOP		BOTTOM				Inn	Inn		
No	PLAYERS			Pos	Pos	Pos	S	R	
1	8	Cole Evans		6					
2	7	Kallan Compain		2					

b. **Uniform Numbers:** Show the player's uniform number in the No. column. You should check these numbers as each player bats. Where a team has no uniform numbers, you can note other identifying features in the margin (e.g. red hair)

TOP		BOTTOM				Inn	Inn		
No	PLAYERS			Pos	Pos	Pos	S	R	
1	8	Cole Evans		6					
2	6	Isaac Fletcher		DP					
	5	Nik Hayes		1					

c. **Player's Names:** Write the name of each starting player on the top line beside his batting order number. If used this applies to Designated Player (DP) and the player he bats for (flexible Player) on the third of the five lines, to allow for substitutes for either.

- Correct spelling is important on the official scoresheet, which can be used by the press.
- Use Christian followed by Surnames e.g. Cole Evans not Evans Cole.

d. **Flexible Player (Flex)** is the starting player who the designated player (DP) is batting for and whose name appears in the 10th position of the team line-up card.

e. **Positions:** Show the starting position numbers for each player as follows.

1. Pitcher
2. Catcher
3. 1st Base
4. 2nd Base
5. 3rd Base
6. Shortstop
7. Left Field
8. Centre Field
9. Right Field
- DP Designated Player
- DR Designated Runner

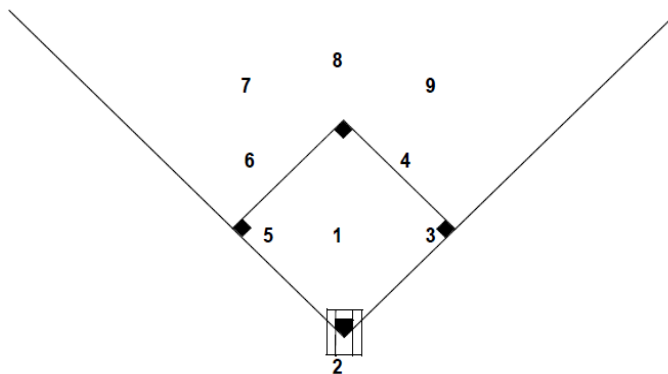

All scorers must be 100% familiar with these numbers when referring to fielders, as they are used on almost every play.

- f. **Designated Runner:** If a designated runner is used, write his name on the 5th line of the number 9 batter in **GREEN**.
- g. **Substitutes:** Write the substitutes name on the lines numbers 10 - 17, below the ninth batter's row. When a substitute enters the game, his position will be one of the positions shown above, or one of the following:

- PH Pinch Hitter
 PR Pinch Runner
 OPO Offensive Player Only

2.4. Team Sheets

At games and tournaments where team sheets are used, the first 9 players named on the team sheet are the starting 9 batters in order including the DP if there is one. The name of the player who the DP is batting for goes on line 10 (Flex Player). If a DR is used his name goes on line 11 regardless of whether a DP is used.

1. Line-up with DP and DR

2. Line-up with DR only

3. Line-up no DP or DR

Softball New Zealand TEAM SHEET					Softball New Zealand TEAM SHEET					Softball New Zealand TEAM SHEET										
Team:		Team A	V	Team B	Team:		Team A	V	Team B	Team:		Team A	V	Team B						
Tournament:					Tournament:					Tournament:										
Time:		2.00pm		Date:	01 August 2017		Time:		2.00pm		Date:	01 August 2017		Time:		2.00pm		Date:	01 August 2017	
Batting Order	Shirt No	NAME (first)	NAME (Surname)	Pos	Batting Order	Shirt No	NAME (first)	NAME (Surname)	Pos	Batting Order	Shirt No	NAME (first)	NAME (Surname)	Pos						
1	89	Ben	Enoka	8	1	89	Ben	Enoka	8	1	89	Ben	Enoka	8						
2	9	Tyson	Byrne	6	2	9	Tyson	Byrne	6	2	9	Tyson	Byrne	6						
3	20	Thomas	Enoka	7	3	20	Thomas	Enoka	7	3	20	Thomas	Enoka	7						
4	15	Brad	Rona	3	4	15	Brad	Rona	3	4	15	Brad	Rona	3						
5	12	Nathan	Nukunuku	9	5	12	Nathan	Nukunuku	9	5	12	Nathan	Nukunuku	9						
6	26	Jovaan	Hanley	DP	6	3	Joel	Evans	4	6	3	Joel	Evans	4						
7	3	Joel	Evans	4	7	13	Zane	Van Lieshout	2	7	13	Zane	Van Lieshout	2						
8	13	Zane	Van Lieshout	2	8	6	Jerome	Raemaki	5	8	6	Jerome	Raemaki	5						
9	6	Jerome	Raemaki	5	9	30	Nik	Hayes	1	9	30	Nik	HAYES	1						
10	30	Nik	Hayes	1	10					10										
11	19	Campbell	Makea	DR	11	19	Campbell	Makea	DR	11										
		SUBSTITUTES					SUBSTITUTES					SUBSTITUTES								
12	5	Heinie	Shannon		12	5	Heinie	Shannon		12	19	Campbell	Makea							
13	50	Connor	Peden		13	50	Connor	Peden		13	5	Heinie	Shannon							
14	29	Wayne	Laulu		14	29	Wayne	Laulu		14	50	Connor	Peden							
15	68	Josh	Harbrow		15	68	Josh	Harbrow		15	29	Wayne	Laulu							
16	14	Kurt	Schollum		16	14	Kurt	Schollum		16	68	Josh	Harbrow							
17					17					17	14	Kurt	Schollum							

2.5. The Game

The 9 columns in the central body of the scoresheet are used to record what happens in each innings during the game. Use a separate column for each innings.

2.6. Game Analysis

The narrow columns on the right of the scoresheet are used to record batting and fielding statistics. Pitching and catching statistics are recorded at the bottom of the scoresheet (refer Section 6 - Analysis).

2.7. Game Summary

The bottom right corner of the scoresheet is used to record summary information and the officials' names (refer para 6.12).

2.8. Game Start Time

Note the time as the umpire-calls or signals "Playball" for the first pitch. Don't forget the finish time at the end of the game (refer para 6.12).

2.9. The Box

Each box shows the progress of the batter/baserunner around the diamond in that innings as follows:

- Batter's box to 1st Base (or 'OUT' before reaching 1st safely)
- 1st Base to 2nd Base (or 'OUT' before reaching 2nd safely)
- 2nd Base to 3rd Base (or 'OUT' before reaching 3rd safely)
- 3rd Base to Home (or 'OUT' before reaching home safely)

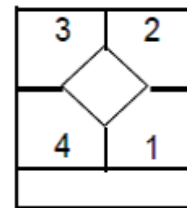

Use the diamond in the centre of the box to record what finally becomes of the player. This must always be one of the following:

Run Scored

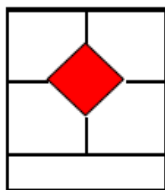

OUT

- 1st Out of the Innings
- 2nd Out of the Innings
- 3rd Out of the Innings

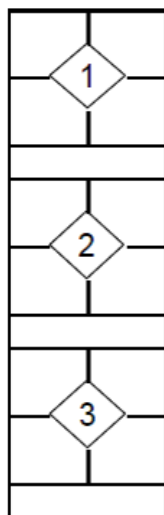

Left on Base

- Left on 3rd base
- Left on 2nd base
- Left on 1st base

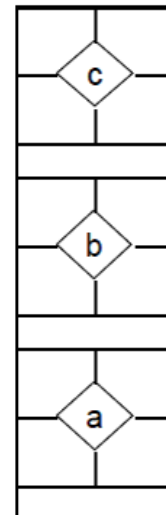

2.10. Closing off the Innings

- At the end of each inning mark a single thick diagonal line after the last player to complete a turn at bat (this is not always the last **OUT** in the innings (Rule 5.4.1c).
- If the game finishes with less than three **OUT** in the last innings (e.g. when the team batting second scores the winning run in the last innings) write 'game' below the end of innings line

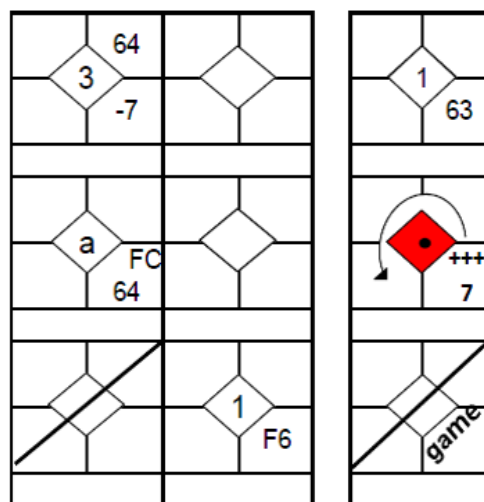

(a)

(b)

2.11. Innings Totals

Record the innings totals at the bottom of each innings column. These provide an instant check on game trends (especially the current score) and give a very useful cross-check later.

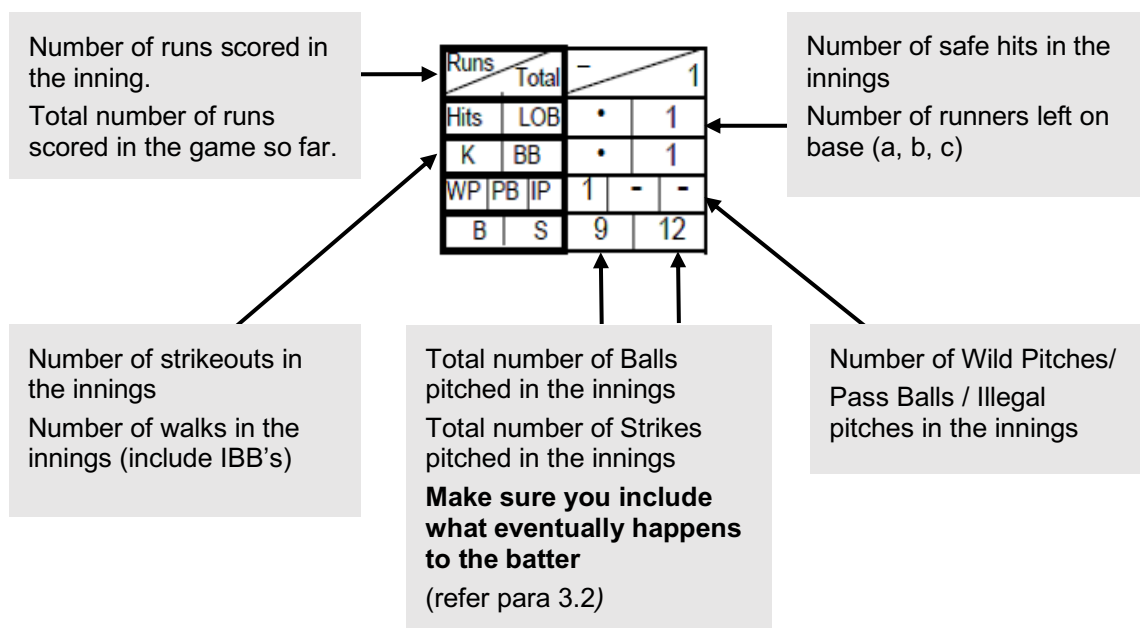

The total number of strikeouts includes anything with a K. There may be more than 3 of these in one innings e.g. K2E3, KFB, KWP, which should all be included in the total strikeouts for the innings. Where a total is nil, use a solid dot (•) or dash (-). This helps to highlight the figures.

2.12. Innings Fielding

This section is an intermediate step toward producing the final game totals, and greatly speeds up the time taken for analysis at the end of the game. Show the fielding numbers (of the opposition) responsible for the 3 putouts and any assists and errors. Transfer the figures down from each innings column (Appendix 6.2b).

- Assists** - Whenever an **OUT** has more than one fielder number shown, all but the last number are assists. Remember an assist can be scored even if no **OUT** eventuates. e.g. on a 4E3 play - 4 must get an assist (refer para 3.31)
- Putouts** - Every **OUT** in a game must be credited to a fielder. Show the fielder number with every putout except K's where it goes to the catcher (but not K23, etc)
- Errors** - Show every number that appears in the innings with an **E** in front of it.

	-	1	-	1
	•	1	3	2
	•	1	2	2
	1	-	-	1
	9	12		
A	5	6		
PO	3	2	4	6
E			4	

2.13. Innings Overflow

- If the ninth batter in an innings is the third **OUT**, show his action in the **same innings** column as shown in innings 5. You may need to shorten the end of innings line to make the scoresheet look tidy.
- If the ninth batter in an innings completes his turn at bat and is **not** the third **OUT**, show his action in the **next** innings column as shown in innings 6.
 - Delete all subsequent innings numbers on the scoresheet.
 - Change innings number to cover all columns and bracket the columns together.
 - Draw curved 'railway tracks' to assist the eye to follow the change of column.
 - Record all putouts, assists, and errors in the column the innings started in.
 - Cross out the innings analysis area under the column extended into.
 - Re-number any other innings column used

(a) (b)

Runs	Total	-	1	-	1	2	6		
Hits	LOB	•	1	3	2	3	1		
K	BB	•	1	2	2	1	1		
WP	PB	IP							
B	S								
A	5		6						
PO	3	2	4	6	2	2	3	6	2
E							4		

2.14. Scoresheet Overflow

On occasions a game will extend past 9 columns (i.e. 9 innings, or less if innings overflow occurs) and require a further scoresheet. If this happens, use the first sheet for all final game totals etc., and clearly mark this sheet '**Sheet 1 or 2**'. Mark the next sheet '**Sheet 2**'.

3. Use of Symbols

3.1. Official Symbols

This section lists all the standard scoring symbols. With each is indicated whether it is used for an 'OUT', or for a 'SAFE' advance. Except for any 'K's all those used to show and 'OUT' include fielders' numbers to provide fielding statistics. Most of the symbols used for runners' advance have the batters number shown in a circle beneath them to assist in reconstruction of the game

BATTING – Symbols used on a batter (although most can involve a runner advancing at the same time)					
—	One Base Hit	S	IF	Infield Fly	O
+	Two Base Hit	S	D	Drive Caught	O
++	Three Base Hit	S	L	Batting Out of Order	O
+++	Home	S	MTB	Missed Turn at Bat	O
A	Automatic (with hit symbol)	S	IG	Illegal Batting	O
⌘	Safe Bunt	S	K	Strikeout	O
⌘	Unsuccessful Bunt	O	KC	Strikeout (3rd strike called)	O
S	Slap Hit	S or O	KA	Dropped 3rd Strike rule	O
SH	Sacrifice Bunt	O	KFB	Bunt Foul on 3rd Strike	O
SHF	Sacrifice Fly	O	KPB	Passed Ball on 3rd Strike	S
F	Fly ball caught	O	KWP	Wild Pitch on 3rd Strike	S
FF	Foul Fly ball caught	O	BB	Walk (Base on Balls)	S
FE	Dropped Fly ball	S	IBB	Intentional Walk (Base on Balls)	S
FFE	Dropped Foul Fly ball	S	HP	Hit by Pitched Ball	S
RUNNER – Symbols used on a runner only					
WP	Wild Pitch	S	IR	Illegal Running	O
PB	Passed Ball	S	MB	Missed Base	O
IP	Illegal Pitch	S	H	Hit by batted ball	O
SB	Stolen Base	S	T	Tagged	O
CS	Caught Stealing	O	AT	Avoiding Tag	O
RI	Runners Interference	O			
EITHER – Symbols used on either batter or runner					
E	Error	S	▼	Double or Triple Play	O
OE	Fielder's Obstruction	S	IS	Illegal Substitute	O
COE	Catcher's Obstruction	S	FC	Fielder's Choice	S
TI	Teams Interference	O			

3.2. Balls and Strikes Count

The balls and strikes are recorded along the line below the bottom of the 'BOX' for each batter.

- Ball
- ! Illegal Pitch (In **RED**)
- C Called Strike (Not Swung at)
- X Strike (Swung at)
- n No Pitch called (Runner called OUT for leaving early attempting to steal)
- b Foul **bunt** (Instead of fielder numbers as below)
- 2 Fouled back (behind the plate)
- 3 Fouled off in 1st Base
- 5 Fouled off in the area of 3rd Base
- 7 Fouled off in the area of left field
- 9 Fouled off in the area of right field
- / Change of pitcher after one or more pitches have been thrown to the batter.

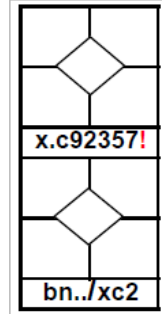

The diagonal black line which separates the pitches thrown by each pitcher helps separate the total pitch count for each pitcher.

When totalling at the end of the innings ensure you include what happens to the batter e.g.

- Inning A: 2 Balls, 6 Strikes.



NOTE:

When there is an IBB or HP record 1 Ball.

- Inning B: 6 Balls, 7 Strikes.

The (n) in the count of batter (c) is an indicator for a no pitch declared when batter (a) is called OUT for leaving early. An error on the batter is counted as a strike. Even though batter (d) has not completed his turn at bat his pitch count is still included.

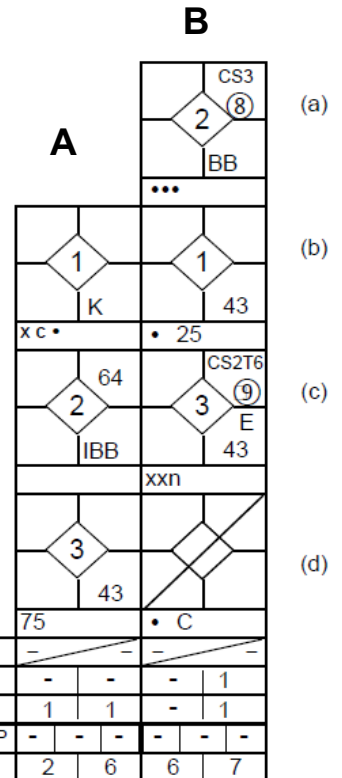

3.3. Safe Hits (-, +, ++, +++)

Use the following symbols to record safe hits. This includes one-base, two-base, three-base hits, and home runs (Appendix 6, Sections, 6, 7 and 8).

3.4. Hit Location

Show the hit symbol with fielders number beneath it. Show where the ball is hit, rather than which fielder retrieves it. If appropriate more than one fielding position may be shown. Use a continuation arrow to show the extra base advances, e.g.

- (a) Infield single to shortstop
- (b) Two base hit to left-field (regardless of who fields the ball)
- (c) Three base hit between centre-field and right-field
- (d) In the park home run to right-field

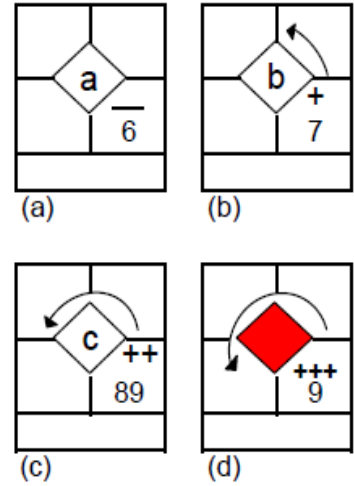

3.5. Extra Base Advance

- (a) Connector

Where a player advances 2 or more bases in continuous play as a result of more than one event in the field, (such as a hit followed by an error), record each play separately. Use a connector to link the plays together.

- (b) Continuation Arrow

Where a player advances two or more bases on a *single play*, use a continuation arrow to show the advance around the subsequent bases. On some plays, it may be necessary to use both a connector and a continuation arrow.

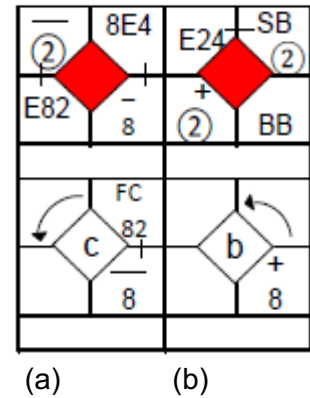

3.6. Runners Advance

When runners advance on a hit, record the play with a batter number shown in a circle beneath the hit symbol. Note that a two-base hit does not mean runners will advance (only) two bases e.g.

- (a) A runner may score from second base on a single.
- (b) A runner may hold up for fear of a catch, and then only advance one base on a double.

Use a batter number in a circle to show at what point in the innings plays on runners occur. These are important for reconstruction of stats such as earned runs and Runs Batted In. Most plays on runners should have a batter number.

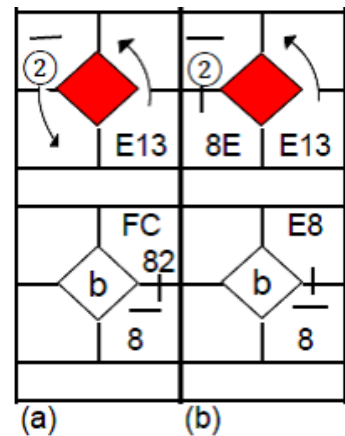

The few exceptions are:

- Where consecutive plays are joined by a connector only the first play needs a batter number
- Double and Triple plays where the other **OUT**(s) are linked to the batter does not require a batter number.
- Fielder's Choice where the play is made on the lead runner and there is an **OUT**
(refer paras 3.33, 3.34, 3.35)

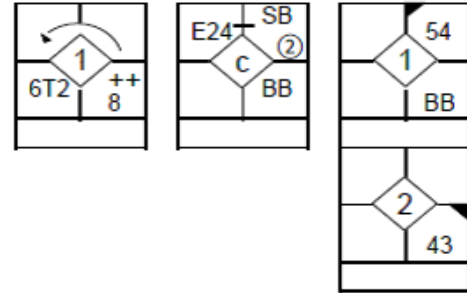

3.7. Automatic Hit (A)

Where a ball is hit over the outfield fence, (or where the ball is blocked in the outfield and the umpire restricts the batter to 2 or 3 bases), show **A** after the fielder number(s), e.g.

- Over the centre field fence on the full = Home Run
- Bounces over the fence at left/centre = 2 Base hit



NOTE: Only show the **A** on the batter. The runners advance is shown the same whether the advance is automatic or not.

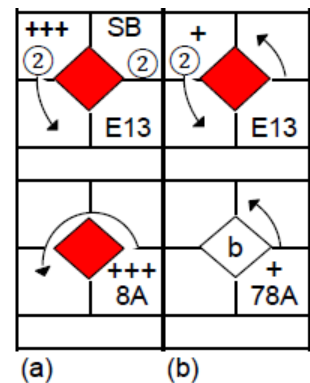

3.8. Length of Hit

Credit the batter with the number of bases he could have made if the ball was played directly on him.

This is an important and common decision for a scorer. If a fielding error on a ground ball hit to the outfield allows a runner to advance further than he would have on the hit, score a hit and then an error, e.g.

- Single to centre field - the runner would have scored anyway, but the batter only went to 2nd on the throw to home.
- Short single to centre field - neither the runner nor the batter would have made more than one base if the error hadn't occurred.

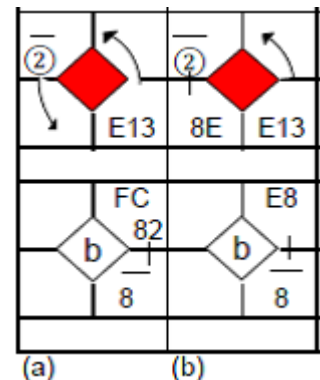

3.9. Slap Hit (S)

When a batter shapes to bunt, but then slaps at the ball show an **S** with the play. This applies regardless of whether the batter is **OUT** or **Safe** at first (Rule 5.1.38).

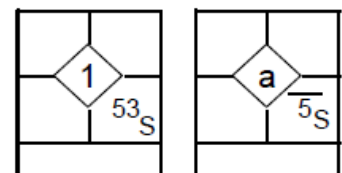

NOTE: A slap hit is not considered to be a bunt.

3.10. Bunt

A bunt is a batted ball not swung at, but intentionally met with the bat and tapped slowly within the **playing field** (Rule 5.1.8).

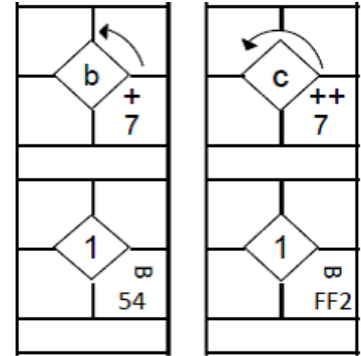

a. Unsuccessful Bunt (⊖)

When a batter bunts, and is taken out without advancing a baserunner, show the unsuccessful bunt symbol as well as the play.



NOTE: In these examples the runner did not advance, so the batter is not credited with a sacrifice (refer para 3.11)

b. Safe Bunt (⊖)

Do not confuse a safe bunt with a sacrifice bunt. A safe bunt is simply a safe hit, which is bunted. Score the batter exactly as for any other safe hit - include the hit symbol, the bunt symbol, and the direction of the hit beneath the hit symbol.

If any other baserunner advances on the play score this exactly the same as an advance on any other safe hit. It is not necessary to include the bunt symbol for a runner's advance.

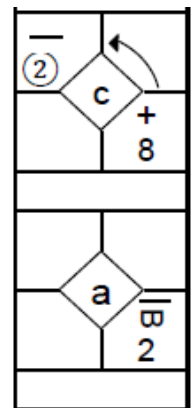

3.11. Sacrifice

A Sacrifice is scored when, with **less than 2 OUTS**:

- A run scores after an outfield fly ball (Appendix 6, Sec 9c)
- A batter bunts to advance a baserunner (Appendix 6, Sec 9a)



NOTE: If an error allows the batter to be safe as well, the sacrifice should still be scored provided the baserunner would have scored or advanced regardless of the error. Refer Section 4 (Multi-Symbol Plays).

a. Sacrifice Fly (SHF)

This **must** score a runner to be classed as a sacrifice e.g.

- Fair ball caught by shortstop running in the outfield - a runner scores after the catch
- Foul ball caught - a runner scores after the catch
- Fair ball caught - a runner scores from *second* after the catch.

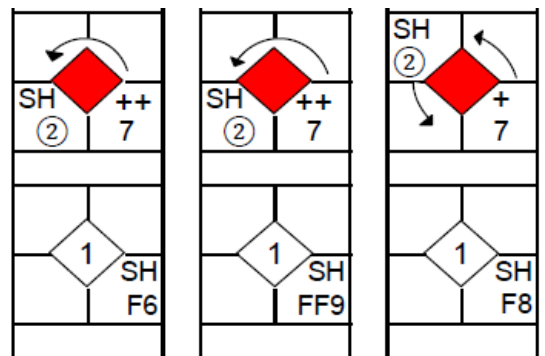

(a)

(b)

(c)



NOTE: For this to be a sacrifice, the runner must go all the way home after the catch, not go from third to home on an error, or because the fielder chooses to play another runner.

b. **Sacrifice Bunt (SH)**

For the batter to be credited with a Sacrifice the lead runner must advance safely, e.g.

- (a) & (b) = Batter bunts and is played **OUT** at first, runner(s) advances one base safely
- (c) = Batter bunts in an attempted Sacrifice but the lead runner is taken **OUT**, so therefore no sacrifice is awarded.

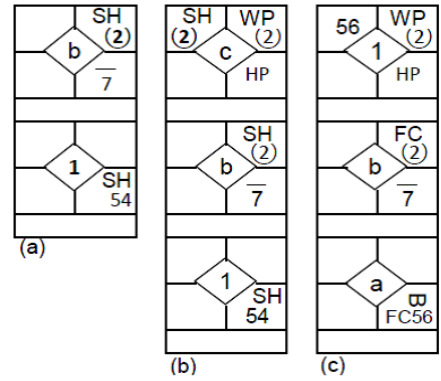

3.12. **Batted Ball Caught**

a. **Fly Ball (F, FF)**

If a fair ball is caught, score F and the fielder who makes the catch. If the ball is foul, score FF and the fielder who makes the catch.

For any runners advancing after the catch show F or FF and the batters number.

In either of these cases if the runner scores after the catch, it must be scored as a SF (refer para 3.11a).

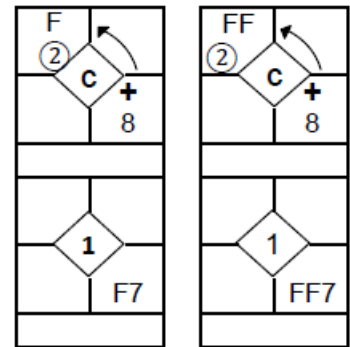

b. **Foul Fly Carried Dead**

When a fielder unintentionally carries a ball dead after making a catch score any runners advance a FF (Rule 5.11.a.ii.3).

In reconstruction for earned runs advance the runner only the number of bases he would have moved if the ball had not gone dead.

If the runner only scores because the ball goes dead, it cannot be a SH or an RBI. If the runner would have scored anyway record a SH and credit the batter with an RBI.

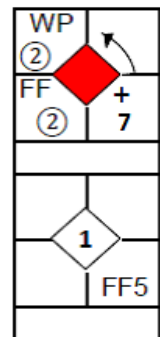

c. **Runner Out After Catch**

There is no symbol for a runner who does not return to his base after a catch and is played **OUT**. Simply show the fielder numbers concerned and mark as a double play (Rule 5.10.3.iv).

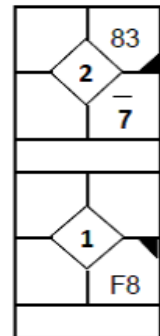

d. **Infield Fly (IF)**

An infield fly is scored only when "Infield Fly" is declared by the umpire. Show fielder who makes the catch, or is nearest the ball when it drops. If an error is made and a runner advances, show the advance as occurring on the error.

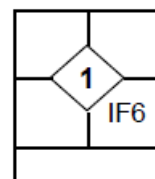

e. **Drive (D)**

When a ball is hit sharply and travels at a near horizontal angle rather than upwards, record the catch as **D** instead of **F**.

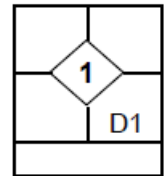

3.13. Batting Out of Order.

When a player bats out of order, the player who *should have batted* is **OUT**. The scorer should be prepared to supply the umpire with full details of who actually batted and when. Hence the importance of checking uniform numbers as every batter comes to the plate. Also advise which runners were on which bases at a given time (Rule 5.4.1).



NOTE: *Batting out of order is an appeal play*, as an official scorer you must remain silent and not volunteer any information unless asked by the umpire.



TIP: Refer to case studies at the back of the manual for further information as team scorer

a. **Batter Called Out (L)**

Where the batter is called **OUT** for failing to bat in the correct order score as L2. Take care to ensure that the correct batter is **OUT** (Rule 5.4.1 effect b).

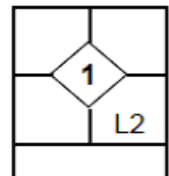

b. **Missed Turn at Bat (MTB)**

If due to batting out of order, whether detected or not, a player misses his rightful turn at bat, mark MTB right across his box (so as not to inadvertently take this to be an 'at-bat' when analysing), e.g. B4 Bats instead of B3, no appeal was made B3 misses his turn at bat.

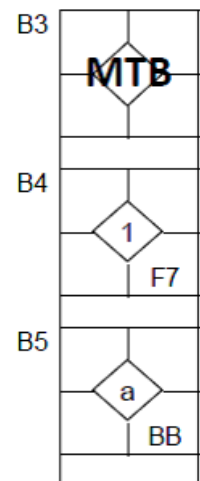

Illegal Substitute (IS)

Where a batter is called **OUT** for any infringement of the substitution rule, score as IS2.

The penalty for infringements of this rule is not always that a player is called **OUT**, this symbol allows for those that are. The umpire will make a ruling (Rules 3.2.8.d, 3.2.8.f, and 3.3 and their effect).

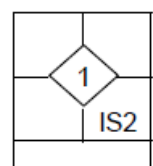

3.14. Illegal Batting (IG)

This symbol covers all of the following infringements:

- a. Batting out of the box (Rule 5.4.4b,iv)
- b. Changing batter's box (Rule 5.4.4b vi)
- c. Using an illegal or altered bat (Rule 5.4.4b, iii)
- d. Hitting ball twice (Rule 5.4.4b, vii)
- e. Batters Interference (Rule 5.4.4b.vi and 5.4.4c)

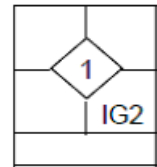

3.15. Strike Out (K)

Due to their frequency strikeouts are the only symbols which do not have a fielder number shown. The putout goes to the catcher on a normal strikeout (Appendix 6, Sec.12b) and the pitcher does not get credited with an assist.

- (a) Third Strike swung at (K)
- (b) Third Strike not swung at but called by the umpire (KC)
- (c) Third Strike bunted foul (KFB)
- (d) Dropped Third Strike, played **OUT** at first

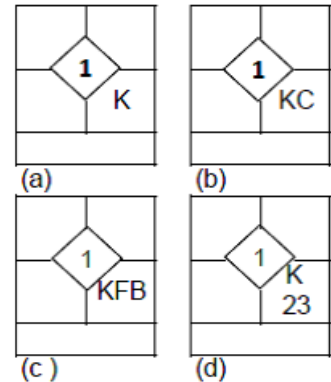

In example (d) the fielder at first base gets the **OUT**, and the catcher gets an assist. The batter is charged with the strikeout, and the pitcher also gets the credit for the strikeout in his pitching stats.

a. Third Strike Not Held

When there is no runner on first base, or whenever there are two **OUT**, if the third strike is not held by the catcher, the batter must be played **OUT**.

Score any advance by a baserunner as a FC, not an E or PB, as an **OUT** was taken (Appendix 6, Sec.14.a.4).

If the catchers throw is too late for the **OUT** at 1st base, you must decide between a PB and a WP. For the baserunners advance use two batter numbers (for example 2/3) to show that one batter (2) has completed his turn at bat, and the next batter (3) is due up to bat.

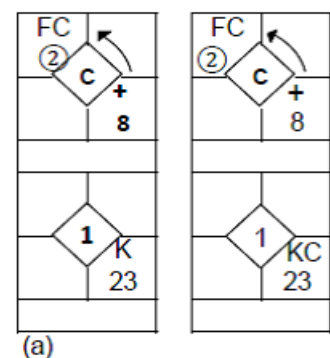

b. Dropped Third Strike Rule

With less than 2 **OUT** and first base occupied, the dropped third strike rule applies - the batter is **OUT**, the runner can advance at his own risk (Rule 5.4.4.a.ii).

- (a) With a runner on second and first base open, the catcher takes the **OUT** at 1st base, and the runner advances on the play (refer para 3.15.a, example a).
- (b) With less than 2 **OUT** and a runner on first base, the batter is **OUT**, the runner can advance at his own risk.
- (c) With 2 **OUT** the batter and runner can both advance

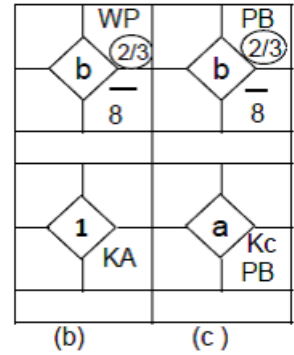

3.16. Walk (BB)

When the batter gets on base with a walk (base on balls or 4 Balls), score as BB for the batter, and advance any runners on a BB with a batter number.

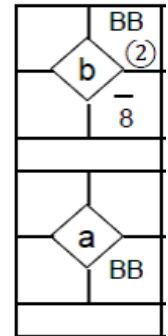

3.17. Intentional Walk (IBB)

For an Intentional walk, score as an IBB instead of BB. An Intentional walk occurs when the defensive team desires to place the batter on first base without the requirement to deliver four pitched balls. This can be indicated any time during the batters turn at bat.

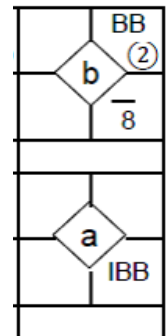

Note: An Intentional walk cannot be an earned run (refer para 6.9)

3.18. Ball 4 on WP or PB

If a WP or PB on ball 4 allows the batter to reach second base show the BB and the WP or PB

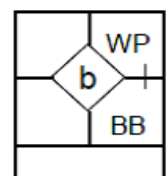

3.19. Catchers Error (BBE2)

When there are no runners on base, the catcher must return the ball directly to the pitcher after each pitch, or the umpire will call an extra ball on the batter. If this is the 4th ball and the batter gets a walk, score the walk and charge the catcher with an error - BBE2

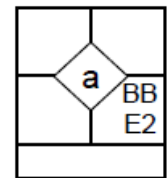

3.20. Hit by Pitch (HP)

When the batter is hit by a pitched ball, score as HP for the batter, and advance any runners on a HP with a batter number.



NOTE: If there were 3 balls on the batter when he is hit, the umpire may have awarded him first base on the BB not the HP if unsure check with the umpire.

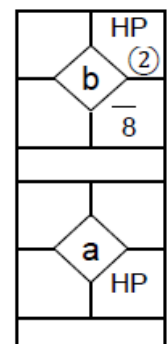

3.21. Battery Errors

a. Wild Pitch/Passed Ball

- A Wild Pitch is a pitch that is so low, so high, or so wide that the catcher is unable to hold it with ordinary effort, and a runner advances (Rule 5.1.49).
- A Passed Ball is a pitch that the catcher should have been able to hold with ordinary effort, and a runner advances (Rule 4.1.5).
- A pitch that hits the ground before reaching home plate is always a WP not a PB.

There may be more than one runner advance on a single WP or PB. To ensure that these instances don't get counted more than once in the pitching or catching stats, put a dot by the WP or PB symbol of the lead runner. These are totalled after each innings and entered in the WP or PB boxes in each innings analysis.

If there is a change of pitcher or catcher during the innings use a diagonal **BLACK** or **BLUE** line to separate them if required. These are then totalled at the end of the game and transferred to the pitching and catching analysis on the other side of the scoresheet.

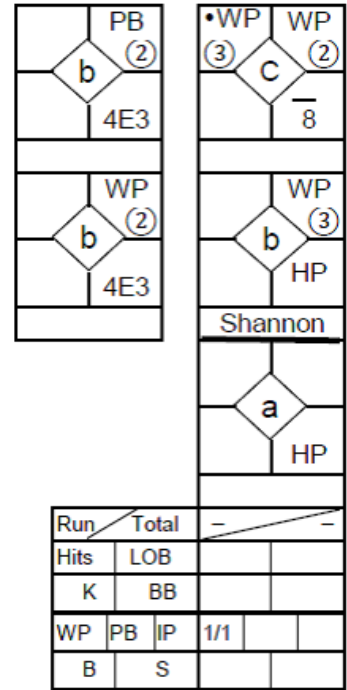

b. Illegal Pitch (IP)

- When there are one or more runners on base, and an illegal pitch is called,
- Advance the runners on an IP (Rule 4.2.1 to 4.3.7 effects). Regardless of whether there are runners on or not the illegal pitch is recorded as a ball for the batter and indicated with a **RED** exclamation mark (!). All illegal pitches should be included in the total in the pitching analysis.
- If the batter hits the ball and reaches 1st base safely and all baserunners advance at least one base the play stands and is recorded how it happened. The illegal pitch is still recorded in the balls and strike (!) and included in the pitching analysis total.
- If the illegal pitch is the fourth ball score both the walk and the illegal pitch (BBIP). This is to show the walk was only given because of the illegal pitch. Score any runner who advances on this play on the IP whether forced to advance by the BB or not. The illegal pitch is still recorded in the balls and strike (!) and included in the pitching analysis total.

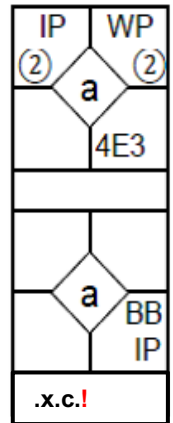

3.22. Base Running

a. Stolen Base (SB)

Stolen Base results from a runner leaving base as the pitch is released and advances one base on the delivery of the pitch. Any other situation should be considered carefully as the advance will almost certainly be 'aided' by some other play (Appendix 6, Sec. 15 and 16).

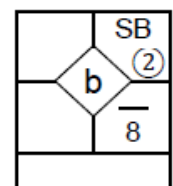

b. **Caught Stealing (CS)**

When a runner is **OUT** attempting to steal a base, remember to include the CS, the play and the batter number. This is very important for pressure batting and can also affect the reconstruction of Earned Runs (Appendix 6, Sec 18).

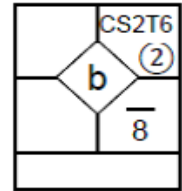

Note: Do not charge a “caught stealing” unless the runner has an opportunity to be credited with a stolen base when the play starts.

c. **Left Base Early (CS)**

When a baserunner attempting to steal is called **OUT** by the umpire for leaving before the pitch is released, score CS and award the putout to the nearest fielder.

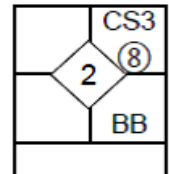

Note: If you judge that the runner was not intending to steal but simply taking a lead off, score as IR (Illegal Running) instead. (*Rule of Thumb: most umpires will only call someone leaving early if they are of the opinion they are stealing.*)

d. **Wild Pitch/Passed Ball**

If the catcher recovers from a WP or PB in time to take the **OUT** a runner trying to advance, only score a caught stealing if the runner was genuinely stealing on the pitch. Otherwise just record the play.

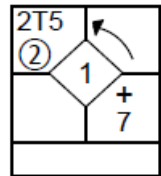

e. **Runners on 1st and 3rd**

This is a common situation, where the runner on 1st goes to 2nd. Do not score as a stolen base when the defence is indifferent to a base stealer’s advance. Unless a play is made on the runner, score as a FC2

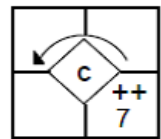

Note: If the runner leaves with the release of the pitch on a genuine steal attempt, not just a lead off and a WP or PB results, he should be credited with a stolen base and the WP or PB ignored (Appendix 6, Sec. 15 b).

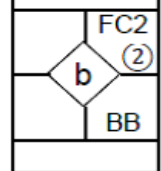

f. **Illegal Running (IR)**

This symbol covers the following (also see Effects following each Rule):

- Running outside the 1 metre line, thus interfering with the throw..... (Rule 5.5.2a.vii and 5.10.3i)
Note: This has **no** connection with ‘AT’
- Running bases in reverse.....(Rule 5.10.3a.vii)
- Passing preceding runner(Rule 5.10.3a.vi)
- Failure to return after suspension of play.....(Rule 5.10.3a.xi)
- Removing batting helmet.....(Rule 5.8)
- Off base when the pitcher has the ball (Rule 5.10.3b.iii) unless stealing (refer para. 3.22c above).

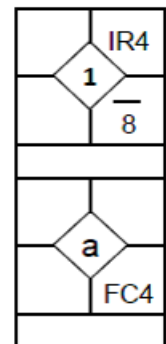
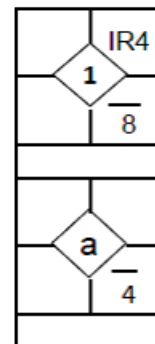

g. Runners Interference (RI)

This symbol covers the following (also see Effects following each Rule):

- Kicking a batted ball..... (Rule 5.10.3c.ii)
- Interfering with a fielder fielding a ball (Rule 5.10.3c.iii)
- Deliberately crashing into a fielder..... (Rule 5.10.3c.ix)

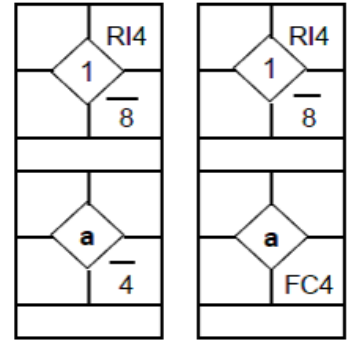

Note: When a runner is out, for illegal running or runners' interference, award a safe hit to the batter if in your judgement he would have been safe had the offence not occurred. Otherwise score a FC (Appendix 6, Sec.7.d).

h. Missed Base (MB)

If a runner is called **OUT** for not touching a base, (including touching the incorrect base when double bases are used), score as a missed base (refer Rules 5.6a.iii and 5.10.3a.iv). A runner **OUT** for missed base is considered only to have safely reached the previous base (Appendix 6, Sec 8.c).

Give the **OUT** to the player who makes the appeal, and credit an assist to any player who throws the ball unless he is quite unaware of the missed base and simply returns the ball to the pitcher.

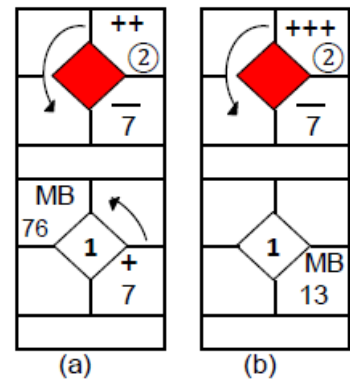

The following examples show when a batter hits an apparent home run, but is then called for missing a base:

- The batter missed 3rd base.
- The batter missed 1st base (this counts as a turn at bat and the batter does not get a hit).
- The batter hits a home run but an appeal is made for missing 1st base although this is the 3rd out the preceding run still scores.

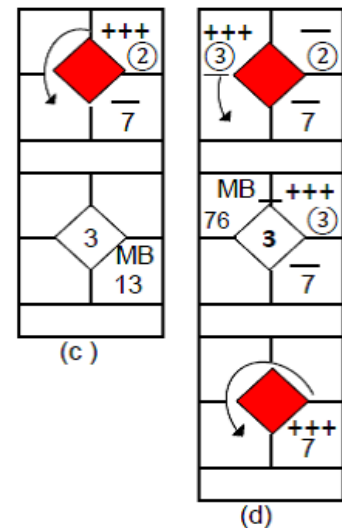

The following example shows when a preceding runner is called out for missing a base and is the third out:

- The batter hits a home run with two runners on base. An appeal is made on the second runner for missing 3rd base. As this is the third out the first runner scores but the batter does not (*also refer Rule 5.9g*).



Note: Show any other runners' advance on the complete hit even though the hit may not be scored as such for the batter.

i. **Hit by Batted Ball (H)**

When a runner is called **OUT** for being hit by a batted ball, show as H and give the **OUT** to the nearest fielder. e.g.

- (a) If the batter would have otherwise deserved a hit, give him a hit
- (b) If he should have been OUT, show as H with the nearest fielders' number (Appendix 6, Sec. 12.4).
- (c) When a batter-baserunner runs into his own batted ball, show as OUT - H2 (Rule 5.5.2b.vi).

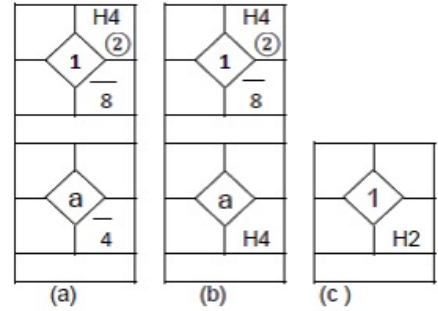

j. **Tag (T)**

When an **OUT** is made by a tag, (even on a force play) show a T directly in front of the fielder who makes the tag (Appendix 6, Sec 12.3).

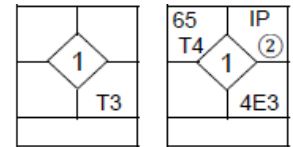

k. **Avoiding Tag (AT)**

When runner is called **OUT** for running outside the 90cm line to avoid a tag score as AT, and give the **OUT** to the fielder who attempts the tag (Appendix 6, Sec. 12.4). Still credit an assist to any player who makes a throw which contributes to the **OUT**.

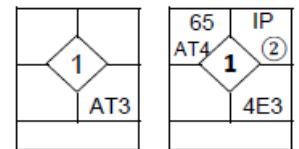

Force Out

There is no symbol specifically for a force **OUT** on a runner. Simply show the fielders involved, as you would if the play was on the batter. Batter numbers are not required on the player who is **OUT**. e.g.

- (a) 1st base takes the force **OUT** at first unassisted.
- (b) Shortstop plays the lead runner at second. The batter is safe on 1st on the FC.

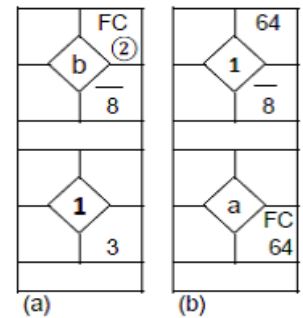

The Force is obvious, as without a force there would have to be a 'T' (Tag) involved.

3.23. Interference

Interference is an act by any member of the batting team (including a coach) which impedes a fielder trying to make a play (Rules 5.1.30, 5.5.2b.vi and 5.5.2b.x).

a. **Batters Interference (IG)**

When a batter interferes with a fielder making a play:

- (a) If the batter is **OUT**, score as illegal batting (IG2)
- (b) If the runner is **OUT**, score as team interference (TI2)

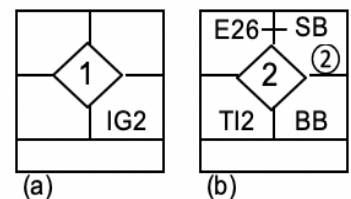

b. **Team's Interference (TI)**

Team's interference refers to an interference caused by any member of the batting team including a coach, e.g.

- (a) On the batter (Rule 5.5.2b.x)
- (b) On the runner (Rule 5.10.3c.iii - v)

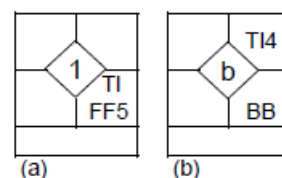

3.24. Obstruction

Obstruction is an act by any member of the fielding team (including a coach) which impedes a batter from hitting a pitch, or impedes a runner attempting to advance (Rule 5.1.32).

a. **Catcher's Obstruction (COE2)**

If the catcher interferes with batter attempting to hit a pitch, score an error on the catcher (Rule 5.5.1d). Score any other runners advancing on the play, as a reverse error (refer para 3.28).

This rule can also be applied to other fielders, e.g. a close-fielding 3rd baseman.

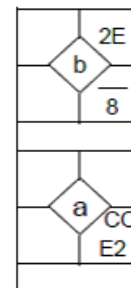

b. **Fielder's Obstruction (OE)**

If a fielder interferes with a baserunner, score an **E** on the fielder (Rule 5.5.1d).

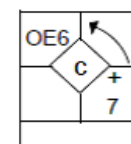

Note: Scoring this error does not mean that the batter cannot be given a hit (if deserved)

3.25. Errors (E)

An error is a mistake by the fielding team, which prolongs the life of a batter or baserunner who should have been **OUT**, or which allows a baserunner to **advance** one or more extra bases that he should not have reached (Appendix 6, Sec 13).

3.26. Scorer's Judgement

A fielder is expected to make a **reasonable effort**, to field a ball. Depending on the play, this sometimes includes moving a step or two towards the ball to make the play. What is considered a **reasonable effort** varies with the standard of softball being played. Premier players should be expected to make **OUTS** that social or age group players are not expected to make, so your judgement needs to be tougher at higher levels of softball.

To decide whether to score a hit or an error, ask yourself:

Should a fielder playing at this level of softball generally be expected to make this Out?

Be careful not to judge the **player** rather than the **play**? An error must not be charged to the best fielder in the league on the basis of '**he** should have had it'. The standard applied must be consistent for all players, depending only on the grade or level of softball being played.

Other questions you should consider are:

- a. Firstly, the prime guide is not 'does the batter deserve a hit?', but 'does the fielder deserve an error?' In considering this remember the key phrase 'reasonable effort' A fielder is only expected to make 'ordinary or reasonable effort', not to be a superman.
- b. What if the error hadn't occurred? If the error didn't affect the outcome of the play, don't score it.
- c. If the OUT had been taken would it have been worthy of applause? (this would surely indicate extra-ordinary effort required).
- d. Did it look like a hit when it left the bat? If so, it should probably be scored as a hit, despite what the fielder did with it.
- e. Slow handling is not classed as an error unless mechanical misplay is involved.
- f. On a bad hop it may seem that the batter does not deserve a hit. But even less does the fielder deserve an error. Generally, the batter gets the benefit of any quirks of the ball he hits.
- g. When a thrown ball hits a runner, a bat, or an umpire when it would otherwise have retired a runner, score an error to the thrower.
- h. When an infield throw bounces before reaching the baseman, thereby allowing a runner to be safe, score an error to the thrower – don't blame the baseman for not picking up the bad throw
- i. When fielders collide attempting to catch a ball, consider the level of softball being played to decide whether the play deserves an error, and who to charge with the error.

3.27. Scoring an Error

Show an error by marking an **E** before the number of the fielder who made the error:

- (a) Use a single fielder number to show a ground ball not fielded cleanly
- (b) Use an FE to show a dropped catch (or FFE for a foul)
- (c) Use a second fielder number to show the direction of a bad throw
- (d) When a thrown ball is errored by the receiver, even though there is no OUT, the thrower still deserves an assist (refer para 3.32). This includes having a foot off the base, or missing a tag.

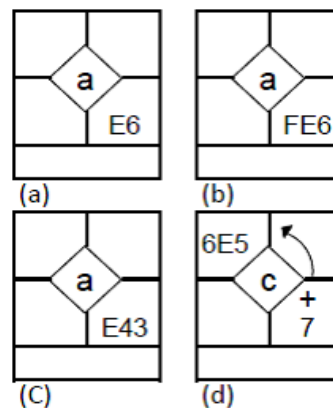

3.28. Reverse Error

If other baserunners also advance due to an error, show the same fielder numbers, but put the **E** last. This helps you to avoid counting the same error twice during analysis.

3.29. Extent of An Error

One error can be responsible for up to 3 runners and the batter all advancing. However, if any baserunners advance was **not** specifically due to the error, the 'E' should not be shown there. This is particularly important for a runner scoring from 3rd base, as it makes RBIs clear:

- (a) If errorless play would not have prevented the runner from advancing, show the advance on a FC. The batter should have been OUT, but the runner would have scored anyway – the batter gets an RBI.
- (b) If errorless play would have prevented the runner from advancing show the advance on the reverse error. The batter should have been OUT, and the runner would not have scored without the error – the batter does not get an RBI.



Note: Whenever there are already 2 **OUT**, all baserunners advances are due to the error

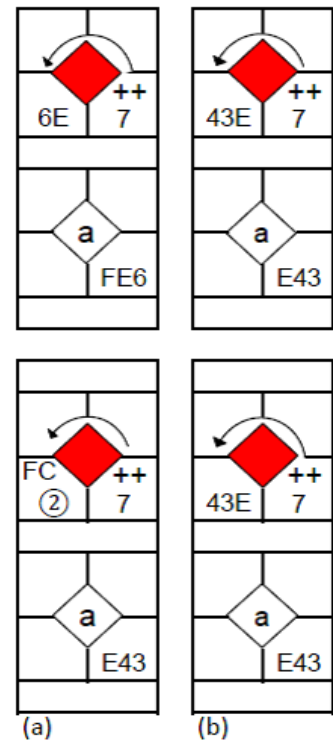

3.30. More Than One Error

Sometimes a fielding team will make more than one error on a single play. However, a single base advance (by one runner) **can not be** the result of more than one error.

Only one of the errors can be the reason for the advance – the other can be ignored (unless the runner advances an additional bases).

Example: The batter hits to shortstop, who fumbles the ball then throws to 1st. First baseman drops the ball and the batter is called safe.

Although both fielders made errors, you can never score this as 'E6E3'. In such cases, you must consider each misplay separately, usually the last one first, and apply the all-important test.

What would have happened if the error had not occurred?

Applying this, first look at what would have happened if 1st base had not dropped the ball?

- (a) The runner would have been OUT. In this case, it is 1st base's error. Because shortstop recovered in time for the out, his error is not counted.
- (b) The runner would have been safe anyway – then you cannot give 1st base an error. In this case look at the shortstop's fumble. What if that had not occurred? If the runner would have been OUT, it is shortstops error.
- (c) If the runner would still have been safe anyway, then neither error affected the outcome of the play – this must be scored as a safe hit for the batter.

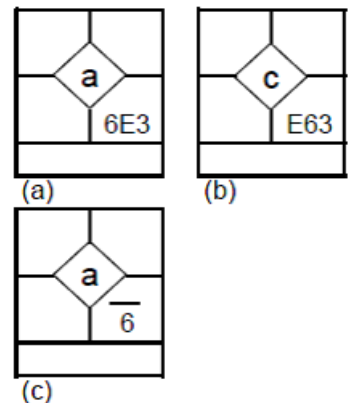

3.31. Out-Errors and Advance-Errors

It is important for the scorer to be familiar with the two different categories of error (Appendix 6, Sec 13).

a. Out-Errors

The most common type of errors are **OUT**-Errors which prolong the life of a batter or runner. (All examples on page 24 are **OUT**-Errors). An **OUT**-Error can occur even when nobody advances.

- (a) Runner leads off first. Catcher throws, first basemen has the runner cold but drops the ball. Runner is safe back at first. Be aware on subsequent plays that this runner is still on 1st base *not* 2nd.
- (b) The catcher drops a foul fly. The batter subsequently gets a 2 base hit.

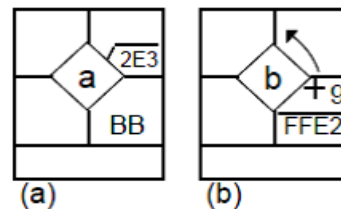

b. Advance-Errors

Advance errors permit runners to advance one or more bases. In no case is there any question of an **OUT**. Therefore, they are advance errors only and fielders involved in the play are not credited with assists. In these situations, show in brackets the numbers of any fielders making throws.

- (a) Runner leads off first. Catcher throws - throw is too late, but 1st baseman muffs the ball so the runner goes to 2nd. Because there would not have been an **OUT** without the error, this is an advance-error - the catcher doesn't get an assist.
- (b) Compare this with an **OUT** error on the same play. If the runner should have been **OUT**, the catcher gets an assist.
- (c) Catcher's throw on a steal is wild, thus allowing the runner to advance an extra base (Appendix 6, Sec 14b).
- (d) After taking a catch, fielder intentionally takes the ball out of bounds (Rule 5.11.b.v effect). Runners are awarded 2 bases from the last base touched at the time the ball is taken over.

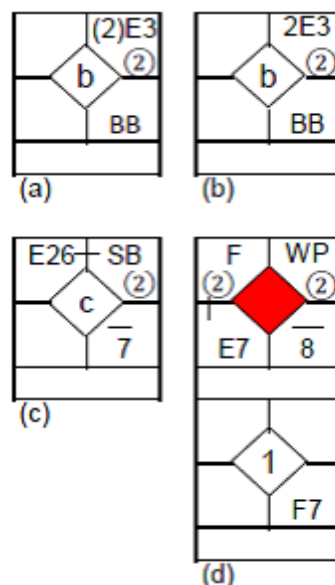

Note - An error is only charged against the fielder if the umpire rules that the play was intentional. If the umpire rules the ball was taken dead unintentionally, then Rule 5.11.a.ii.3 applies. (refer para 3.12b)

3.32. Assists with Errors

When an error occurs, other fielders who have done their job properly should not be penalised. If a fielder would have had an assist had the error not been made, then the assist should be recorded (Appendix 6, Sec 10.a).

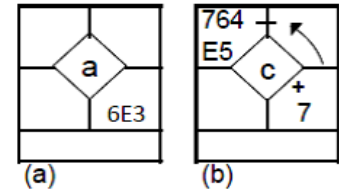

Where an **OUT-Error** occurs after receiving a thrown ball, include the number(s) of the thrower(s). Even though no **OUT** was taken, each player who participated in the play must still get credited for an assist.

3.33. Fielder's Choice (FC)

Score a FC when a base advance is due to a fielder retiring another runner, or for any reason choosing *not* to play directly on the runner making the advance:

- If the play is made on the batter, use batter numbers to show runners advances on the play.
- If the play is made on the lead runner, batter numbers are not required.
- However, if a run scores on the play, always put a batter number on the runner coming home. This is to ensure that the RBI is not missed.

3.34. Fielder's Choice on a Batter

Score a Fielder's Choice on a batter who reaches base safely.

- When a fielder takes an **OUT** (force or otherwise) on a preceding runner. This is usually an 'FC' on the batter, even if he could have beaten the throw to first. (Appendix 6, Sec 7.b).



Note: When the batter hits into a force out with 2 down he must be shown as reaching first base, even though he may actually stop before getting to first.

- When a fielder either misses an **OUT** on a proceeding runner, or
- Attempts to hold a proceeding runner. Attempting to hold includes looking at or dummied toward the runner before playing the batter, or merely holding the ball.
- When a fielder should have an **OUT**, but choose to hold the ball because there is no fielder covering the base to throw to.

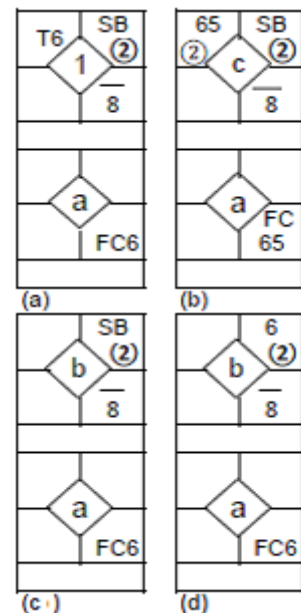

When no **OUT** is made, you should always ask yourself, would the batter have beaten a direct throw to first?

- If the answer is no - score it as a FC. In (b) and (d) score the play or player holding on the runner with the batter's number.
- If the answer is yes - score it as a hit

3.35. Fielder's Choice on a Runner

Score a FC on a runner who advances due to a fielder attempting to retire or hold another runner (whether successful or not).

- Outfielder tries for the **OUT** at home, choosing to ignore the batter-baserunner, who goes to 2nd on the throw. FC82 shows where the throw was made.
- 2nd base takes the batter **OUT** at first, but the run scores from 3rd base on the play. Because the throw is recorded on the batter, it is not necessary to show it on the runner as well.
- Where the fielder merely holds the ball, show FC with that one fielders number. Shortstop holds the runner at 2nd, then plays 1st too late. The runner from 2nd goes to 3rd on the throw. In this case, it is necessary to show 2 separate FCs. The batter made base on shortstop's delayed throw (FC6). The runner advanced only after the throw was made (FC63).
- With a runner on 3rd base, the catcher chooses not to play the runner going to 2nd in case of the run scoring.

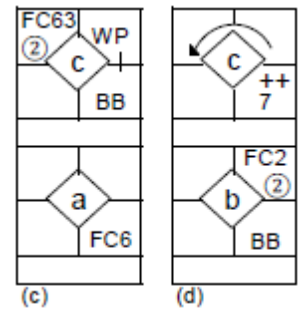
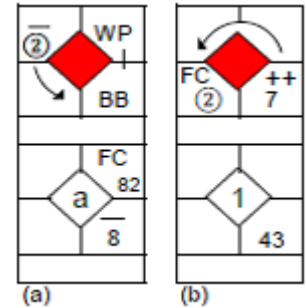

3.36. Second Phase Play

In most cases where an **OUT** is made on a runner, the batter does not get a hit. However, if the **OUT** is made in second phase play, the batter may still deserve a hit. This includes:

- A baserunner holds up for fear of a catch, but the ball falls well short of the outfielder, and the runner is subsequently **OUT** on a force play or a tag.
- A batter beats out an infield single, and then the runner who has lead off is tagged **OUT** off base.

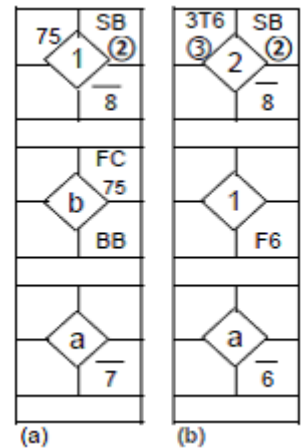

3.37. Double and Triple Plays

- A Double Play is a play in which two players are legally put **OUT** as a result of continuous action.
- A Triple Play is a play in which three players are legally put **OUT** as a result of continuous action.

Show a double or triple play by linking the plays together using mitres (triangles) in the corner of the boxes where the **OUTS** were made.

These two examples show the **OUTS** being made on runners advancing toward the next base

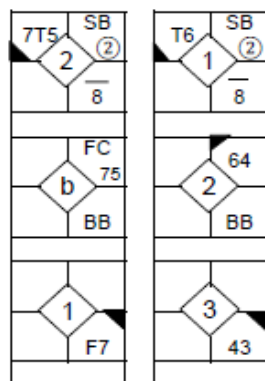

These two examples show the **OUTS** being made on runners returning after a catch to the base they were on before the pitch.

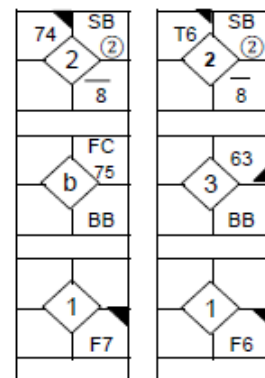

4. Multi-Symbol Plays

Section 3 (Use of Symbols) lists all symbols with their individual uses. However, plays frequently occur which require a combination of symbols. This happens especially with errors, where the important question for the scorer must always be: **What if the error had not occurred?**

4.1. Error on a Foul Fly

A dropped foul fly which could have been handled with ordinary effort must be recorded as an error. (It clearly prolongs the life of the batter). Show in the bottom corner with a solid line above to separate from the batter's subsequent action.



The FFE is ignored for the batter's analysis, but may vitally affect earned runs, and will also affect the fielder's figures.)

4.2. Error on Sacrifice Fly

When a fly ball is dropped with a runner on 3rd and less than 2 **OUT**, consider "**What if the error had not occurred?**":

- If the catch had been made, would the run have scored anyway? If so, it must be scored as a SH
- If you do not believe that the runner could have scored after the catch, or if there were two **OUT**, score both the batter and the runner as advancing on the E.

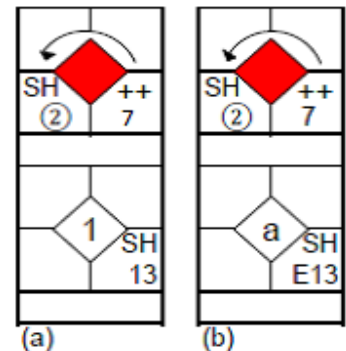

4.3. Stolen Base Attempts

There are a number of scenarios which affect Stolen Bases:

- If the catcher makes a bad throw, no error is charged unless the baserunner makes an extra base (refer para 3.31).
- When a runner steals and should have been **OUT**, but for the fielder's error, credit the catcher with an assist, and charge the fielder with an error. It is important to also include the CS and the batter number.
- If the catcher's throw is good but there is no fielder at the base, credit a stolen base. If the runner advances an extra base score as a FC on the player who was not there.

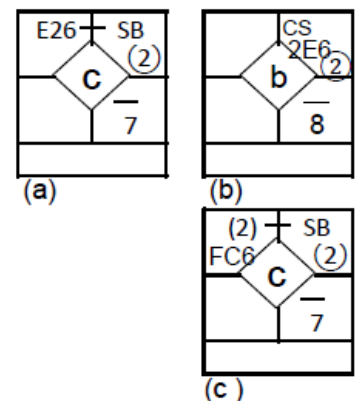

4.4. Double Steal

Examples of double steals:

- Catcher makes a play on runner going to 3rd, score a SB on the 1st runner and a FC on the runner going to 2nd.
- Catcher makes a play on the runner going to 2nd, score a SB on this runner and a FC on the runner going to 3rd base



Note: If the Catcher makes **no** attempt on either runner credit both runners with a SB and the catcher with two SBs.

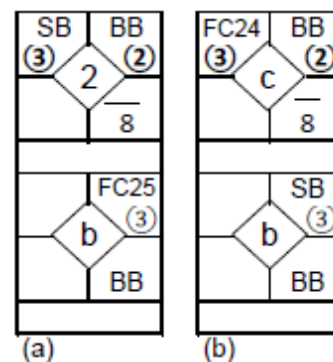

4.5. Sacrifice Bunt, Error, Fielder's Choice

It is important to understand the principles behind scoring these common plays. Besides providing a very good insight into the logical approach needed by scorers, they also directly affect player's statistics.

Some basic rules of thumb are:

- Try to give the batter what he deserves when hits the ball, regardless of what the fielders do
- If an error had no bearing on runners advance it is not shown on the runner (example b).
- A Sacrifice Hit can never be scored when there are already two OUT.**

In the following examples there are no **OUTS**, a runner on 3rd, and the batter bunts toward pitcher.

- Pitcher throws to 1st, **OUT**. Runner scores. The batter has advanced the runner, so is credited with a sacrifice.
- Pitcher throws wild to 1st, safe home and first. The E13 is obvious, but the batter should not then be deprived of what would have been a sacrifice if fielded properly.
- Pitcher tries for tag at home, too late. He had plenty of time for the **OUT** at first. Again, the batter has advanced the runner, so is credited with a SH and a FC.
- Pitcher tries for the **OUT** at home but throws wild (in the scorer's opinion he would otherwise have had the **OUT**).

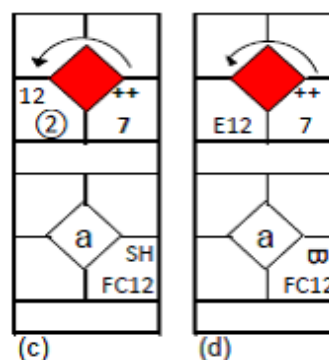
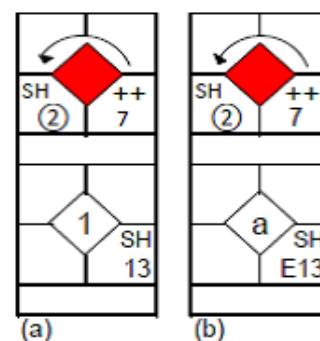

Note: In example (d) the run scored solely due to the error. Therefore do not score a SH.

- Pitcher plays the runner **OUT** at home.
- Pitcher dummies runner back, then plays 1st, too late. runner holds.

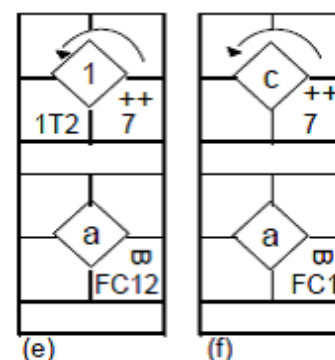

Note: In examples (e) and (f), the batter cannot be credited with a sacrifice, as no runner actually advanced.

4.6. Tie Breaker

If the score is level after the 7th Innings, the batter that last completed his turn at bat starts the 8th Innings on 2nd base, and the who would normally come up to bat, is the batter. The symbol for the runner on 2nd is shown at right.

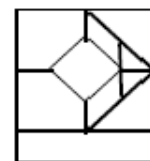

 **Note:** In accordance with International rules, the tie-breaker starts from the 8th Innings.

4.7. Fast Pitch

In fast-pitch the game is sometimes played with runners on base every innings.

The symbols for the runners are:

- a. Runner starts on 1st Base – innings 1, 4, 7
- b. Runner starts at 2nd Base – innings 2, 5
- c. Runner starts at 3rd Base – innings 3, 6.

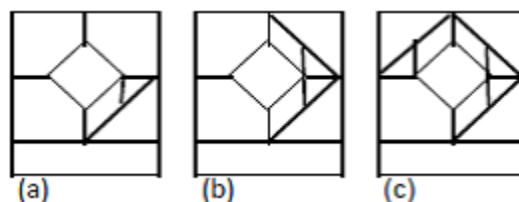

5. Substitutes and Position Changes

Correct marking of all player changes is vital. Even the best box score is rendered useless if it cannot be ascertained who all the players were at any given time. Special care should be given to changes of pitchers.

5.1. Substitute

Write the name of a substitute immediately below the player substituted for. His position will either be:

- 1-9.
- DP - Designated Player (player batting for the Flex or defensive player only).
- PH - Pinch Hitter (for a substitute batter who never gets to play in the field).
- PR - Pinch Runner (for a substitute runner who never fields or bats).
- OPO - Offensive player only (This occurs when the designated player [DP] and flexible player [flex] are fielding at the same time and this player stay's in the batting line up as a batter only).



Note: You cannot confirm the position of pinch hitter or pinch runner until you see whether the replacement player stays in when the team take the field.

Use the substitute's **S** column to show when he entered the game. Show the innings number, and fill in the top-right or bottom-left corner of the square to show which half of that innings.

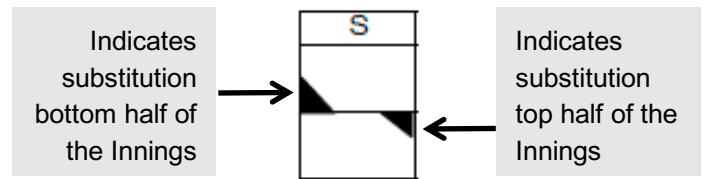

5.2. Change Indicator Lines

Change indicator lines are used to ensure that the analysis is credited to the correct player.

a. Batting

- Whenever a new batter enters the game, write his shirt number, name and position on the line below the player he replaces.
- Mark a vertical line to the left of his batting box in the next innings column.
- If the substitute batter is later replaced (including a re-entry or another substitution) mark another vertical line after his batting box to show that any further batting belongs to the next substitute. This will clearly highlight the change when compiling batters' totals.

4	20	Thomas Enoka	3	/	/	/	/	/										
	15	Brad Rona	3				3			2					a			
										F7					7			

b. Re-entry

When a starting player re-enters the game, use his R column similarly to the S column use in para 5.2.a above (Rule 3.19).

The diagram shows a scorecard for Thomas Enoka (No. 20) and Brad Rona (No. 15). Thomas Enoka is the pitcher (PH) and Brad Rona is the batter (3). The diagram includes a diamond for Enoka's first pitch (2), followed by a diamond for Rona's batting box (a) and another diamond for Enoka's next pitch (7). A vertical line is drawn to the right of the batting box, indicating Rona's re-entry.

c. Baserunning

When a player enters the game as a **runner** mark a short line showing which base he ran from.

The diagram shows a scorecard for Thomas Enoka (No. 20) and Joel Evans (No. 3). Joel Evans is the batter (PR) and Thomas Enoka is the pitcher (PH). The diagram includes a diamond for Enoka's first pitch (2), followed by a diamond for Evans' batting box (a) and another diamond for Enoka's next pitch (7). A short horizontal line is drawn above the batting box, indicating Evans' baserunning.

If the runner stays on as a substitute fielder, mark a vertical line to the right of the batting box. This will ensure that any subsequent batting is not credited to the original batter.

The diagram shows a scorecard for Thomas Enoka (No. 20) and Joel Evans (No. 3). Joel Evans is the batter (PR) and Thomas Enoka is the pitcher (PH). The diagram includes a diamond for Enoka's first pitch (2), followed by a diamond for Evans' batting box (a) and another diamond for Enoka's next pitch (7). A vertical line is drawn to the right of the batting box, indicating Evans' baserunning.

d. Fielding

For every defensive change, including a new player brought into the game, the exact point of entry into the inning must be shown (on the opposite half of the sheet). Mark a horizontal line above the box of the next batter due up. If fielding changes occur at different times within one innings, these must be distinguished apart. Fielding analysis will also be helped by putting the lines in the fielding summary at the bottom of each column. Also, refer to para 5.3 for Blood Bin examples.

e. Pitching

Whenever a new pitcher takes over, write his name in the balls and strikes area above the indicator line. If there are already a lot of balls and strikes you may need to write it below the line.

The diagram shows a scorecard for Cole Evans (No. 8) and Kallan Compain (No. 7). Cole Evans is the pitcher (PH) and Kallan Compain is the batter (2). The diagram includes a diamond for Evans' first pitch (1), followed by a diamond for Compain's batting box (2) and another diamond for Evans' next pitch (7). A horizontal line is drawn above the batting box, indicating Evans' baserunning. A red diamond is drawn in the batting box, indicating a strike.

f. **Position Change**

When any player changes fielding position, including a re-entry in a different position, show innings number and new position number in the Inn/Pos column.

TOP		BOTTOM		Inn		Inn			
No	PLAYERS	Pos	Pos	Pos	S	R			
1	20 Thomas Enoke	7	8	3	8	1			



TIP: Top/Bottom of the innings does not need to be indicated.



Note: While teams are morally obliged to advise the Official Scorer of any position changes, this does not always happen. Therefore you should always be alert for switching of players in the field.

A team scorer should ensure that all changes by her team are advised to the umpire, the official scorer and the opposition team scorer.

g. **Designated Player (DP)**

When a designated player is used, write his name on the top line of that batting row. Write the name of the player playing defence only (flexible player) on the third line of that batting row. This allows for a substitute for each player.

If the Designated Player (DP) takes the field for the flexible player (flex) or the flex player bats, the game can continue with 9 (nine) players. In this case show this in the Inn/Pos fields for the player who left the game. Use a dash (-) to show “no position”.

In the example, Hayes bats in the 5th, Enoke has temporarily left the game, he re-enters in the top of Inning 7 to bat and remains in the game as pitcher in the bottom of 7.

TOP		BOTTOM		Inn		Inn			
No	PLAYERS	Pos	Pos	Pos	S	R			
1	20 Thomas Enoke	DP	5	7	1	7			
	18 Nik Hayes	1	7	-					
	5 Josh Pettet	1				5			



TIP: Refer Case Study at para 9.3 for more DP examples.

h. **OPO (Offensive Player Only)**

This can occur when a team is using a Designated Player and they decide to use the Designated Player (DP) and the flex player in the field at the same time but wish to retain the 9 batters who are batting at the time. The batter the DP is fielding for becomes the OPO, and the DP still bats as well.

TOP		BOTTOM		Inn		Inn			
No	PLAYERS	Pos	Pos	Pos	S	R			
1	12 Nathan Nukunuku	3	4	OPO					
2	15 Brad Rona	DP	4	3					
	18 Nik Hayes	1							

i. **Designated Runner**

When a Designated Runner is used, write his name on the bottom line of the ninth batting row in **GREEN**. If you have a substitute **DR** you need to use the line above.

9	25 Campbell Enoke	9					
	3 Joel Evans	DR					



Note: Although the original DR is part of the starting line-up he **may not** re-enter.

When the DR comes into the game, mark the baserunning change indicator line at the base he runs from, as you would for a pinch runner, only mark it in **GREEN**.



TIP: Remember when you do your analysis to record any runs, SB or CS against the DR, not against the player he ran for. Do the same for a runner replacing the catcher in the 2 down catcher rule situation.

5.3. Blood Bin

When a player is replaced under the blood bin rule, the replacement player can stay in the game until the end of the next complete innings without becoming a substitution.

a. **Scoring Blood Bin Changes**

Show the number, name, position and innings for all blood bin changes, including change indicator line in **RED**, but score the plays in the game in your normal colour.

	What Happens	How to Score it
1	A blood bin change is made	Write the shirt number, name, position of the replacement player, and the innings, on the bottom line of the original players batting row in RED .
2	The original player returns	Write the innings in the Inn column and nothing in the Pos column (unless he comes back in a different position - write the new position in the Pos column).
3	The original player does not return	If the replacement stays in the game and becomes a substitute, copy his shirt number, name and position in your normal scoring colour (black or blue onto the line below the player he replaces. If another player comes in treat it as a normal substitution.
4	Other players change position	When players change position because of the blood bin rule show their position changes in your normal scoring colour.
5	Subsequent changes	Only the blood bin changes are scored in RED . If a player is later a substitution, re-entry, or changes position score in your normal scoring colour.

b. Blood Bin Examples

Batter 1:

- Bottom 2 - **Ferrisco** replaces Cooper at 2nd.
- Top 4 - Cooper returns from the blood bin.

Batter 2:

- Bottom 4 - **Makea** replaces Werahiko as a runner.
- Top 5 - Werahiko returns from the blood bin.
- Bottom 6 - Makea replaces Werahiko at left field. This time it is a substitution, not a blood bin replacement.
- Top 7 - Werahiko re-enters.

Batter 3:

- Bottom 2 - Bromhead replaces Gettins at catcher.
- Top 4 - Gettins re-enters.
- Bottom 5 - **Avery** replaces Gettins but goes to 1st base. Nukunuku (Batter 4) goes to catch.
- Top 7 - Gettins returns from the blood bin, and goes to 1st base.

Batter 4:

- Top 7 - Gladding replaces Nukunuku as catcher (substitution).

TOP	BOTTOM		Inn	Inn		
No	PLAYERS	Pos	Pos	Pos	S	R
1	14 Ellie Cooper	4	4			
	26 Danica Ferrisco	4			2	
2	24 Mikayla Werahiko	7	5	BB		7
	1 Mereana Makea	7			6	
	1 Mereana Makea	PR			4	
3	8 Melanie Gettins	2	7	3		4
	6 Kyla Bromhead	2			2	
	16 Kingsley Avery	3			5	
4	12 Katrina Nukunuku	6	5	2		
	25 Meg Gladding	2			7	

c. Analysis

Make sure that the analysis goes to the correct player - combine all analysis for one player together:

- If a player only participates in the game once as a blood bin replacement, put his analysis on the same line as his name.
- If a player participates in the game more than once, but still only as a blood bin replacement, put all of his analysis on the line where he first came into the game.
- If a starting line-up player becomes a blood bin replacement, put his analysis on the line where he started the game.
- If a blood bin replacement later comes into the game as a substitution, put all of his analysis on the line where he became a full substitution.
- If any player fields in more than one position, remember to split the fielding analysis.

6. Analysis

After the game, show game totals in each category for each player. In most cases, where a total is nil, leave it **blank**. Exceptions are; AB, RCH and RAB in the batting analysis and ALL boxes in the pitching and catching analysis.

6.1. Batting and Running Summary

Symbol	Meaning	Details
PA	Plate Appearances	The number of times a player appeared at the plate as a batter
AB	At Bat	PA - minus BB, SH, HP, CO (if there are none put in a dash)
BB	Intentional Walks	Number of Walks Including Intentional Walks (IBB)
SH	Sacrifice Hits	The number of Sacrifice Hits, including SHEs and SHFCs (Refer Section 3.11)
HP	Hit by Pitch	The number of times he was awarded 1st Base for being hit by a pitch
CO	Obstruction	Catcher's Obstruction
H	Total Hits	The total of all hits (Including 2B, 3B, HR)
2B	Two Base Hits	Two Base Hits
3B	Three Base Hits	Three Base Hits
HR	Home Runs	Home Runs
RBI	Runs Batted In	The number of runs he batted in
K	Strike Outs	Include every strikeout (K, KC, KA, KFB, KWP, KPB)
SB	Stolen Bases	Include every Stolen Base
CS	Caught Stealing	Include CSE and left base early (Refer Section 3.22)
OE	On Error	Reached base on an error (Except CO error) include SHE, SHFC, WP, PB, FC when preceding runner reaches base on an error.
FC	Fielder's Choice	Reach base on a FC where no error is involved and no out is taken on the play.
Note: The OE and FC columns are used to help balance the Reach		
R	Run	The number of Runs he scored.
Rch	Reach Base	Every time a batter reaches 1st base without an OUT being taken including errors. If there is no Reach put a dash in here
RAB	Reach At Bat	The number of chances to Reach Base - this is all PA's except a routine SH where the batter is OUT .

6.2. Analysis Examples

Where a player never comes to bat or run, put a line right through his batting and running columns, except the flex player. if they do not bat put a dash in the PA, AB and RCH, RAB columns.

TOP		BOTTOM		Inn			S		R		10		HP																	
No	PLAYERS	Pos	Pos	Pos	S	R	10	PA	AB	BB	SH	CO	H	2B	3B	HR	RB	K	SB	CS	OE	FC	R	RCH	RAB	A	PO	E	POS	
1	46 Tyron Bartorillo	6	5	4	5	5																								
2	7 Kallan Compain	2	3	8	5	2																								
	68 Josh Harbrow	PR																												
	13 Zane Van Lieshout	2																												
3	29 Wayne Lauulu	DP																												
	15 Brad Rona	DP																												
	18 Nik Hayes	1																												
	5 Josh Pettett	1																												

← Batting
← Running
← Fielding

When a player comes into the game and bats only put a line through the fielding columns. This does not apply to the Designated Player (DP).

TOP		BOTTOM		Inn			S		R		10		HP																
No	PLAYERS	Pos	Pos	Pos	S	R	10	PA	AB	BB	SH	CO	H	2B	3B	HR	RB	K	SB	CS	OE	FC	R	RCH	RAB	A	PO	E	POS
1	46 Tyron Bartorillo	5																											
	6 Issac Fletcher	OPO																											
2	7 Kallan Compain	2																											
	68 Josh Harbrow	PH																											
3	29 Wayne Lauulu	DP																											
	15 Brad Rona	DP																											
	18 Nik Hayes	1																											
	5 Josh Pettett	1																											

6.3. Runs Batted In

Credit the batter with a run batted in when a run scores as a direct result of his turn at bat. Don't confuse calculation of an RBI with that of an earned run. For an RBI look at each run individually and only the final advance matters, i.e. 3rd to home (Appendix 6, Sec 5).

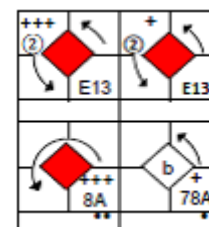

This includes scoring on any hit, a sacrifice hit, and a walk or hit pitch with loaded bases. It also includes a run scoring on a fielder's choice or an error where the run would have scored anyway. Remember that the run scored by a batter who hits a home run is an RBI, as well as any other runners that score on the play.

6.4. Reach Base

In the Reach Base (RCH) column record the number of times the batter makes it safely to first base without an **OUT** being taken. In the Reach at Bat (RAB) column record the number of opportunities the batter had to make it safely to first base. This is every PA except an **SH** where the batter is **OUT**. Although normally sacrifices are excluded from the calculation of the reach base average if an error on a sacrifice play allows the batter to reach base, then this is counted as a reach. Therefore, it must also be counted as an opportunity to reach base.



TIP: Refer to the Case Studies at para 9.4 for further information on Reach Base

6.5. Splitting Batters

It is most important, when a substitute or positional change is made, to ensure that the analysis is given to the correct player.

6.6. Pressure Batting

A batter is under pressure when he comes to the plate and there is a runner on base and they remain there for their entire turn at bat.

To indicate use a **RED** dot in the top right corner of the batter box. This helps to distinguish between dots used to show pressure batting and runs batted in.

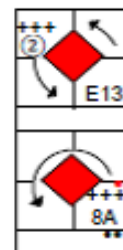

a. Pressure Batting examples

- **Innings 1 – 4:** Batter is under pressure as a runner is on base till the completion of their turn at bat.
- **Innings 5 & 6:** Batter is not under pressure as the runner is either **OUT** or comes home before the completion of their turn at bat.

1	2	3	4	5	6
WP ②	WP ②	BB ②	64	E26-SB ②	CS3 ②
SH ②	b BB	BB ②	1 7	KWP	2 7
1 F7	a BB	7**	a Fc 64	a 7	a 7

6.8. Pitching and Catching Summary

On each half of the sheet list names of all players who pitched or caught **for that team**. Their figure figures will come from the **opposition's** side of the scoresheet.

PITCHER	BF	W	L	INN	K	BB	R	ER	H	2B	3B	HR	WP	HP	IP	CATCHER	SB	CS	PB
Hayes	24	1	-	5	9	1	4	2	5	1	1	-	-	1	-	Compain	-	-	1
Pettitt	7	-	-	2	3	-	1	-	-	-	-	-	-	-	-	Van Lieshout	1	1	-
																	1st B	1	CS
	31	1	-	7	12	1	5	2	5	1	1	-	-	1	-		1	2	1

Symbol	Meaning	Details
BF	Batter Faced	Number of batters he pitched to
W	Win	For the winning pitcher, show 1 under W. For other pitchers on the team show a dash (Refer Section 6.8a)
L	Lose	For the losing pitcher, show 1 under L. For other pitchers on the team show a dash (Refer Section 6.8a)
INN	Innings Pitched	The number of innings, including part innings, he pitched (Refer Section 6.8b)
K	Strikeout	Include every strikeout (K, Kc, KA, KFB, KWP, KPB, K with Error)
BB	Walks	All walks given up including IBB
R	Total runs allowed	Record all runs against the Pitcher who puts the runner on base. Include the Tie Breaker runs if any.
ER	Earned Runs	Earned Runs allowed (Refer Section 6.9)
H	Hits	Total Hits allowed. The Total includes H, 2B,3B, HR, safe Bunt.
2B	Two Base Hits	All Two base hits allowed.
3B	Three Base Hits	All Three base hits allowed.
HR	Home Run	All Home Run hits allowed.
WP	Wild Pitches	Total Wild Pitches thrown. (Refer Section 6.8c)
HP	Hit Pitch	Total batters hit by a pitch.
IP	Illegal Pitch	Total illegal pitches thrown. Including those called where there is no runners advance. (Refer Section 3.21b)
SB	Stolen Bases	Record all successful Stolen Bases against each Catcher
CS	Caught Stealing	Record all Caught Stealing made by each catcher Note: This does NOT include CS for Left Base Early (Refer Section 3.22 c)
PB	Passed Balls	Record all Passed Balls given up by each catcher (Refer Section 6.8c)

a. **Winning and Losing Pitcher**

In every game there must be **one** pitcher from the winning side credited with the win, and one from the losing side charged with the loss. The rules for deciding which player gets the win or the loss need only be applied to a team that used more than one pitcher, otherwise it is automatic (Appendix 6, Sec 17 & 18).



Tip: If a game becomes tied at any stage it becomes a new game for calculating the winning and losing Pitcher.

b. **Innings Pitched**

Where pitchers are changed during an innings, calculate the breakdown by the number of **OUTS**. e.g. If the pitcher is replaced with 1 **OUT** in the 2nd, he has pitched 1.1 innings (one innings and on **OUT**). Remember, if a game ends with only 1 or 2 **OUT** in the bottom of an Innings e.g. **7th** (due to a result being reached) the pitcher for the opposition team would only have pitched either 6.1 or 6.2 innings in total.

c. **WP, PB and IP**

One wild pitch, passed ball, or illegal pitch may have allowed 2 or 3 runners to advance, and therefore may appear 2 or 3 times on the scoresheet. It must still only be counted as one WP, PB, or IP in the pitching and catching stats. To ensure this does not happen we can put a dot above the first advance (refer para 3.21a).

6.9. **Earned Runs**

Earned Runs are runs that would have scored even if the team's fielding had been perfect. Earned Runs are probably the hardest single thing for most scorers to master. This is because you sometimes have to make guesses about what might have happened if an error had not occurred.

a. **Definition**

An Earned Run is a run for which the pitcher is held accountable. In determining earned runs, the innings should be reconstructed without the errors (which includes catcher's obstruction) and passed balls. The benefit of the doubt should always be given to the pitcher in determining which bases would have been reached by errorless play (Appendix 6, Sec 18).

b. **Reconstruction**

To determine earned runs, each innings must be reconstructed as if no errors or passed balls had occurred. Of prime importance is the distinction between **OUT**-errors and advance- errors (Refer Section 3.31). Where an **OUT**-error occurred, reconstruction must show the player as **OUT**, but for an advance error it will show him still alive on base, but not advanced.

c. **Showing Earned Runs**

Mark runs that are earned with a dot in the centre of the run. Optionally, a **RED** dot can be placed in the bottom corner of the “3rd to home” box to show a run that is earned. This can help identify earned runs when a scoresheet is photocopied, faxed or scanned (black and white).

In this example, if the E13 error had not occurred, the first batter would have been out. Therefore, this run is not earned. The dots show that the home run is earned.

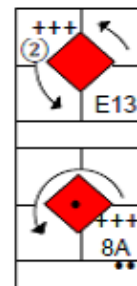

d. **General Hints**

Use these hints to make your reconstruction easier.

- If an innings contains no-errors and no passed balls (and is not a Tie-Breaker), all runs scored will be earned runs.
- Difficult innings are easier reconstructed on paper. Use a spare column on the same scoresheet, and erase afterwards, or use a spare scoresheet.
- **Tie-Breaker:** The tie-breaker runner cannot be an earned run. When you reconstruct a tie-breaker innings, include all the plays involving the automatic runner in your reconstruction, but if the tie-breaker runner scores do not mark the run as earned (see example on the right).
- **Lead Runner:** If the lead runner is taken **OUT** in the actual play, if there is still a lead runner on base when you reconstruct the innings assume that the lead runner would also be taken **OUT**.
- **Catcher’s Obstruction (COE2):** This is an advance error, not an **OUT** error. In reconstruction you must ask - what would have happened if the error had not occurred? The answer is you can’t be sure. Therefore, you can’t blame the pitcher for putting him on base, nor can you credit him with an **OUT**. The only option is to reconstruct the play as a missed turn at bat.
- **Catcher’s Error (BBE2):** This is also an advance error, not an **OUT** error. Treat this the same way as catchers obstruction. Reconstruct the play as a missed turn at bat.

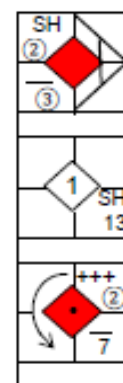

Like us on the New Zealand Softball Scorers Association Facebook page and get the latest information on softball scoring in NZ. It is a collaborative space to share anything to do with softball scoring.

Search “**NZ Softball Scorers Association**”



6.10. Reconstruction Examples

The examples on the following page show a number of common principles involved in the reconstruction process.

	Play	Principle
1	COE2	Catcher's Obstruction is not the pitchers fault, but neither can you say it would have been OUT , so it can only become a missed turn at bat. Any subsequent plays involving this runner are ignored.
2	(2) E3	This is an advance-error . The runner would have been safe back at first base, and free to advance on the next play. Just because there is an error does not necessarily mean that a run cannot be earned
3	FC62	In reconstruction there would not have been a play at the plate. It is possible that the lead OUT could have been taken at 2nd, but unless you are really sure you cannot assume it. An OUT was taken, so it's reasonable to assume that the batter would have been OUT , and Runner 2 would most likely have advanced on the play.
4	+++78	Runner 2 would certainly have scored on the triple.
5	FFE2	Batter 5 should have been OUT on the foul fly. Therefore, any baserunner advance because of the subsequent SHF8 by the batter must be ignored.
6	9	Runner 4 would have scored on the hit by Batter 6.
7	PB	Although PB advances are ignored for Earned Runs, the runner would have scored the subsequent 3-base hit anyway, so this run can be earned.
8	E26	There are two issues on the pick-off attempt. If the runner was at 1st base, would the pick-off still have been made, and was it an OUT-Error ? You can only guess, but you know that without the error, the runner wouldn't have advanced, so don't advance him.
9	WP	A WP can normally be an Earned Run, but this one occurred after the last OUT should have been taken.
10	FC5	With one OUT in actual innings, 3rd base chose to hold the runner on third. Reconstruction has two OUT , so it is reasonable to assume he would have taken the OUT at 1st to end the innings.

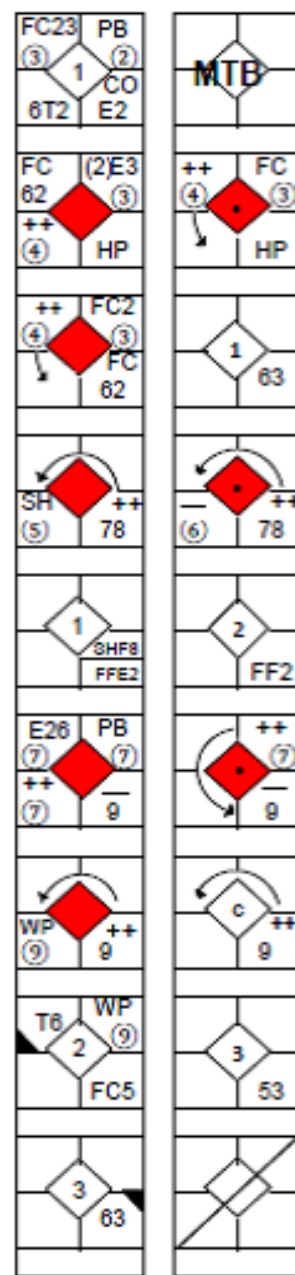

TIPS:

- Once three **OUTs** are reached in reconstruction no further runs in the inning can be earned.
- Even a clean home run is not automatically an earned run.
- A Tie-Breaker runner cannot be an earned run (*but another runner who makes base on a fielders choice which retires the tie-breaker runner can be an earned run*).

6.11. Reconstruction Examples

The following are some examples of an innings reconstruction. Study them to help you understand.

	Original	Reconstruction	Original	Reconstruction	Original	Reconstruction	Original	Reconstruction
1								
2								
3								
4								
5								
6								
7								
8								
9								
		1 Earned Run		1 Earned Run		2 Earned Runs		3 Earned Runs



TIP: Refer Case Study at para 9.5 for some practice examples

6.12. Game Summary

When the game is complete, check that you have filled in the game summary.

Summary	Details
RUNS	The final score for the team. While this can be taken from the innings analysis Total for the final innings, it should be re-checked against the box score. This figure should be written very prominently.
HITS	Total of innings analysis Hits for every innings written in RED in the last Innings analysis.
ERRORS	Total of the E Column in the fielding analysis for this team. You should check this against the Total of the innings analysis on the oppositions side of the scoresheet.
LOB	LOB Total of innings analysis LOB for every innings written in RED in the last innings analysis.
TIME	For the end show the exact time of the final OUT . Record the time and reason for any delays throughout the game. Total time will include any such delays. Write the total in minutes.
UMPIRES	Show each umpires name (preferably in full) against the appropriate base. If not all three are used leave blank.
SCORER	If no scorers name is shown it effectively invalidates the scoresheet. The scorer's name must be legible. Preferably printed and initial beside. If a different scorer analysis the game record both names in here.

Runs	Total
Hits	LOB
K	BB

3	3
6	3
2	1

RUNS	3	HITS	6	ERRORS	4	LOB	3
------	---	------	---	--------	---	-----	---

A		9
PO		21
E		4

OFFICIALS	
PLATE	Lance Brown
1ST	Mark Porteous
3RD	
SCORER	Lynnette Leathart LL

TIME	
FINISH	4.15pm
START	2.30pm
TOTAL	105 Mins

Notes:



- If another scorer analyses the game record their name as well.
- If another scorer does electronics record their name as well.
- Remember to initial beside your name

6.13. Proving the Box Score

Proving the Box Score is compulsory. This helps you to check for and identify mistakes in the analysis of the game. At the bottom of the batting and fielding analysis columns Total each column in **RED**, these also help to check the pitching totals are correct.

100% is the only standard of accuracy to be achieved, so the completed sheet must be cross-checked thoroughly. This is the most effective way of picking up many mistakes (but not all).

Symbol	Meaning	Where to find this information
Runs	Runs Scored	Total Runs scored by the team
LOB	Left on Base	Total Runners left on Base
Pos	Putouts	Total Putouts made by the opposing team. Total of the PO column in the fielding analysis from the opposite side of the scoresheet.
Fielding analysis must be done before proving the Box Score, this will ensure you get the correct figure for proving your box score.		
-TB	-Tie Breaker	Subtract 1 for each innings that started with a runner on base
AB	At Bat	Total of the AB Column
BB	Base on Balls	Total of the BB Column
SH	Sacrifice Hits	Total of the SH Column
HP/CO	Hit Pitch/Catchers Obstruction	Total of HP and CO Columns

Example

If the game was won with 2 OUTS in the bottom of the 7th innings, your proving of the Box Score would look something like this.

If the Box Score totals do not balance, there must be an error somewhere in your analysis.

PA	AB	BB	SH	CO	H	2B	3B	HR	RBI	K	SB	CS	OE	FC	R	RCH	RAB	A	PO	E
30	24	2	3	1	6	-	-	-	-	5	-	-	-	-	5	9	21	10	20	2

RUNS	5	HITS	6	ERRORS	2	LOB	5
------	---	------	---	--------	---	-----	---

PROVING THE BOX SCORE			
Runs	5	AB	24
LOB	5	BB	2
POs	20	SH	3
-TB	-	HP/CO	1/-
TOTAL	30		30

6.14. Tie Breaker

If a game goes into a Tie-Breaker, use the -TB to allow for the Tie-Breaker runners.

a. Proving the Box Score:

If the game was won in the 8th innings, your Proving the Box score would look like this.

Runs	2	AB	26
LOB	4	BB	2
POs	24	SH	1
-TB	-1	HP/CO	-
TOTAL	29		29



Notes

- The tie-breaker run **can be** a Run Batted In.
- The tie-breaker run **cannot** be an Earned Run

6.15. Fast Pitch

In a fast pitch game there will be a -TB in every innings.

a. Proving the Box Score:

When proving the box score subtract 1 TB for each innings that started with a runner on base. If the game was won in the 7th innings, your proving of the box score would look like this.

Runs	15	AB	26
LOB	4	BB	6
POs	21	SH	1
-TB	-7	HP/CO	-
TOTAL	33		33

6.16. Cross Checks

If the Box Score does not balance the best place to start is to count the number of batters, this should be equal to the Box Score Total, and = the total PA, and = the total BF on the **opposite** half of the sheet. Even when the box score does balance, there are a number of other simple cross checks you should do to help confirm that the rest of your analysis is correct.

1. PO's should equal the number of innings the team **batted** times the number of **OUTS** per innings, e.g. for a **full** 7 innings game: $7 \times 3 = 21$; for an incomplete 7 innings game: $6 \times 3 = 18 + 2 \text{ OUTS} = 20$.
2. Total PA = Total AB + BB + SH + HP + CO
3. Total PA = Total BF in pitching summary on **opposite** half of sheet.
4. Total H, BB, K in batting summary = Total HOB, K in innings analysis.
5. Total H, 2B, 3B, HR, K, BB in batting summary = Total H, 2B, 3B, HR, K, BB in pitching summary on **opposite** half of sheet.
6. Total A, E in fielding summary = Total A, E, in innings analysis on **opposite** half of sheet.
7. Count the runs coming home that qualify as RBI's = Total of RBI Column.
8. Check that all Errors and Assists with Errors in the body of the scoresheet are carried down.
9. Check that you have split the analysis for all batting, running, pitching, fielding and catching substitutes
10. Check that you have split the analysis for all fielding positional changes.

The example below is a cross section of what the top and bottom analysis area of a scoresheet is like. Refer to the key for corresponding totals.

Cross Check score sheet Colour coded

Top Half of scoresheet										Bottom Half of Scoresheet									
Innings Analysis										Innings Analysis									
Pitching Summary										Catching Summary									
Runs	Total									Runs	Total								
Hits	LOB									Hits	LOB								
K	BB									K	BB								
WP	IP									WP	IP								
B	S									B	S								
A	PC									A	PC								
E										E									
BP	W	L	INN	K	BB	R	ER	H	2B	BP	W	L	INN	K	BB	R	ER	H	2B
									HR										HR
									WP										WP
									HP										HP
									P										P
									CATCHER										CATCHER
									SS										SS
									CB										CB
									PB										PB
30	1	-	7	3	2	2	1	3	1	28	1	-	7	3	2	2	1	3	1
Pitching Summary										Catching Summary									

PROVING THE BOX SCORES

Runs: 5 AB 22 HTS 5 ERRORS 1 LOB 3

POs: 21 SH 2

HP/CO: 1/-

TOTAL: 28 28

BATTING SUMMARY

Runs: 6 AB 22

LOB: 3 BB 2

POs: 21 SH 2

HP/CO: 1/-

TOTAL: 28 28

Bottom Half of Scoresheet

Runs: 2 30 2 3 1 3 2 1 6 30 6 21 2

Hits: 2 HTS 3 ERRORS - LOB 2

POs: 4 SH 1

HP/CO: 1/-

TOTAL: 28 28

PROVING THE BOX SCORES

Runs: 2 AB 22 HTS 3 ERRORS - LOB 2

POs: 4 SH 1

HP/CO: 1/-

TOTAL: 28 28

OFFICIALS

PLATE: _____

1ST: _____

3RD: _____

SCORER: _____

KEY:

- Yellow: Correspond on both sides Except OO
- Blue: Correspond on opposite sides
- Green: Correspond on opposite sides
- Red: Count in Body of scoresheet
- Light Green: Correspond to opposite side
- Light Blue: These numbers should correspond with the totals of the matching columns
- Light Purple: Correspond On the same side
- Light Orange: Corresponds to opposite side '3 E.G 7x3=21 or 6.1 (part Innings) x 3=18

6.17. Tied Team Score

At a tournament where teams complete round robin play with an equal win - loss record it may be necessary to use the tied team formula to determine the final placings.

The Tied Team score is the number of runs scored by each team at the end of the last completed **EVEN** innings, except that if a team batting second wins in a partly completed innings, that innings may be counted. In simple form the tied team score is usually the same as the game score, the example below shows the only scenario where the tied team score is different to the game score.

Example

The game ends at the top of 7th. The game score is 2-1. Because the team batting 1st score a run in the Top of 7th and the team batting second did not get the opportunity to have their 7th turn at bat, meaning the teams did not have an **EVEN** amount of chances. The Tied Team Score for this game would be 2-0.

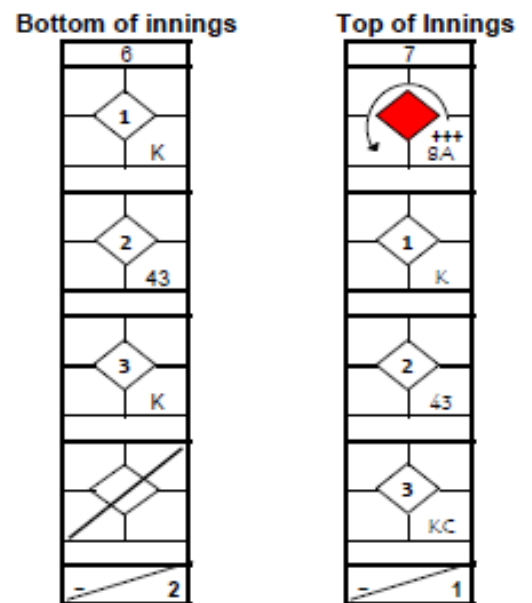

7. Scorers and Umpires

7.1. Official Scorer - Duties

- Before the game, you should make yourself known to the umpire, and advise him where you will be located during the game.
- During the game you should be ready to advise him of the state of the game when asked, especially the number of **OUTS**, or the ball and strike count.

This applies especially when a game ends. It is your duty as the official scorer to advise the umpire if the end is before the 7th innings, due to the application of the mercy rule (Rule 1.2.3).

However, you must be 100% sure of your facts. You should also be prepared to promptly advise the umpire if there are only **two OUTS** when teams change over.

7.2. Tied Team Formula

The tied team formula is used to determine placings or seedings where two or more teams finish with the same win – loss record.

- If two teams tie, rank them on the basis of **who beat who** – use the result of the game **last** played between them, winner placed above loser.
- If three or more teams tie for any position and cannot be graded by this method (i.e. if one team has not beaten all others) then use the tied team formula:
 - Calculate the run ratio of games played between the tied teams grading them from the highest to the lowest ratio.
 - If this does not completely separate them, calculate the run ratio of runs scored in all games played in the round robin.
 - If two or more teams still have the same ratio, rank them in order of the total runs each team scores in the round robin.



Note: The run ratio (i.e. runs for divided by the runs against), is calculated on the runs scored at the last completed even innings, except that if a team batting second wins in partly completed innings (one run) that innings may be counted (refer para 6.17).

Example – Using the run ratio to separate the three tied teams on 4 points

	HV	WR	TA	WN	Points	Placing
Hutt Valley		9-0	1-7	5-1	4	3
Wairarapa	0-9		0-13	2-15	0	4
Taranaki	7-1	13-0		0-7	4	2
Wellington	1-5	15-2	7-0		4	1

HV	For	Against
vs TA	1	7
vs WN	5	1
Total	6	8
Run Ratio	6 / 8 = 0.75	

TA	For	Against
vs HV	7	1
vs WN	0	7
Total	7	8
Run Ratio	7 / 8 = 0.87	

WN	For	Against
vs HV	1	5
vs TA	7	0
Total	8	5
Run Ratio	8 / 5 = 1.60	

Therefore, the top 3 final placings in **run ratio** order are: Wellington 1st, Taranaki 2nd, Hutt Valley 3rd.

7.3. Protests

A scorer should be aware of the various conditions surrounding protests (Rule 1.2.9), and be prepared to record all details of the game at a point where notified by the umpire. Details may include the time of the protest and handy hints.



TIP: Also see the Illegal Substitution Rule (Rule 3.1.10).

7.4. Umpires Decisions

A scorer shall not make a decision which conflicts with an umpire's decision (Appendix 6, Sec. 1). As the scorer you must score as per the umpire's decision even if you saw the play differently.

Example:

- a. A batter cannot be given a safe hit if the umpire calls him **OUT** at 1st base.
- b. The umpire calls safe at 1st on a 63 play, but you are sure that 1st baseman had the ball in time for the **OUT**.
 - If he says that the 1st baseman had his foot off the base, give the 1st baseman an error (6E3).
 - If he says that the batter beat the throw, give the batter a hit to $\overline{6}$.

7.5. Runs Scored

Runs are what wins games!

A scorer should be familiar with Rule 1.2.5. However, the umpire has the final say, and should be consulted at once if there is **any** doubt. Especially important are non-force time element plays,

- a. There is 1 **OUT**—runners on 2nd and 3rd—the batter flies to right field:
 - After the catch the right fielder throws to shortstop who tags **OUT** the runner from 2nd sliding into 3rd. Did the **other** runner cross the plate before the 3rd **OUT** was made? This is solely the Umpire's decision. Unless you are **very sure**, ask the Umpire for a ruling.
 - Don't confuse this with an appeal for the runner from 2nd leaving before the catch. This is a **force play**, and in this case the run does not count.
- b. You could easily miss a run if a runner on 3rd scores quickly on a WP or PB, then the innings ends on the very next pitch. Therefore, you should check you have the right runners on each base at every spare moment, especially when an innings ends.
- c. If a game ends with an automatic home run all runs count, even if one run is enough for the win.

8. Statistics

8.1. Types of Statistician

There are two types of statisticians, each with quite different functions:

- **Tournament Statistician:** appointed by the association or club organising a tournament. Responsible directly to the tournament organisers for providing an accurate record of the games.
- **Team Scorer– Statistician:** appointed by, and part of a team, and responsible for scoring the games and providing statistics to the team coach.

8.2. What Statistics are Required

A proficient scorer will be aware of the possibilities, so always be open minded to investigate new ones.

- Before a tournament starts, determine what trophies or awards are to be presented. Get this information from the N.Z. Softball tournament representative, or the tournament organiser. Introduce yourself to the tournament selector(s) and determine what statistics he or she wants.
- Before a season starts, ask the team coach what he or she requires for team statistics and how often.

8.3. Preparation of Statistics

The main steps in preparation of statistics are:

1. Ensure that all games for the tournament or team for the period are accounted for.
2. Before transferring the figures from the scoresheet, check that all stats have been completed correctly, and that nothing has been left out e.g. Earned Runs, Reach Base, RBIs, SBs, CSs, POs etc.
3. Carefully transfer figures to a statistical programme. SNZ use StatTrak.
4. Statistics must be raised for every player, who appears in any game, but not for a reserve that never plays. This applies to all batters, fielders, runners and pitchers.
5. **Name:** Use Christian and Surnames and include shirt numbers.
6. **Position:** A player who did not field should be shown as DP, PH or PR (or DR).
7. **A, PO, E:** Where more than one position is played by any one fielder in the same game, divide the fielding columns into the number of lines required.
8. Give the coach an up to date list of team stats at regular intervals determined at the start of the season, or as requested by the coach.

8.4. Expressing Averages

Averages (or percentages) are generally expressed correct to 3 decimal places. The only exception is ERA which is correct to 2 decimal places, and should include the number before the decimal point as well.

BA	6 Hits in 12 At Bats	$6/12 = 0.50$	Express as .500
W/L	4 Wins and 7 Losses	$4/11 = 0.363636$	Express as .364
FA	3 A's, 6 PO's, 1 E	$9/10 = 0.90$	Express as .900
ERA	21 innings, 4 Earned Runs	$28/21 = 1.333333$	Express as 1.33

8.5. Common Averages

Average	Formula	Information																					
Batting Average (BA)	$\frac{\text{Hits}}{\text{At Bats}}$																						
Reach Base Average (RBA)	$\frac{\text{RCH (H+BB+HP+CO+OE+FC)}}{\text{AB+BB+HP+CO+SHE+SHFC}}$	This is also sometimes called the On Base Percentage (OBP)																					
Pressure Batting Average	$\frac{\text{Hits+SH+FC(RBI)+BB(RBI)}}{\text{AB+SH+BB(RBI)}}$	With runners on when he completes his turn at bat - not when he enters the box																					
Fielding Average (FA)	$\frac{\text{A+PO}}{\text{A+PO+E}}$	Show each position separately, although the outfield can be combined. <table border="1" style="margin-left: 20px;"> <tr> <td>46</td> <td>Tyron Bartorillo</td> <td>A</td> <td>PO</td> <td>E</td> <td>POS</td> <td></td> </tr> <tr> <td></td> <td></td> <td>1</td> <td>1</td> <td>1</td> <td>4</td> <td>AVE = (1 + 1) ÷ (1 + 1 + 1) = .667</td> </tr> <tr> <td></td> <td></td> <td>1</td> <td>3</td> <td>1</td> <td>6</td> <td>AVE = (1 + 3) ÷ (1 + 3 + 1) = .800</td> </tr> </table>	46	Tyron Bartorillo	A	PO	E	POS				1	1	1	4	AVE = (1 + 1) ÷ (1 + 1 + 1) = .667			1	3	1	6	AVE = (1 + 3) ÷ (1 + 3 + 1) = .800
46	Tyron Bartorillo	A	PO	E	POS																		
		1	1	1	4	AVE = (1 + 1) ÷ (1 + 1 + 1) = .667																	
		1	3	1	6	AVE = (1 + 3) ÷ (1 + 3 + 1) = .800																	
Earned Run Average (ERA)	$\frac{\text{ER x 7}}{\text{Innings Pitched}}$	<table border="1" style="margin-left: 20px;"> <tr> <td>INN</td> <td>ER</td> <td></td> </tr> <tr> <td>7</td> <td>4</td> <td>AVE = (4 x 7) ÷ 7 = 4.00</td> </tr> <tr> <td>5</td> <td>1</td> <td>AVE = (1 x 7) ÷ 5 = 1.40</td> </tr> </table>	INN	ER		7	4	AVE = (4 x 7) ÷ 7 = 4.00	5	1	AVE = (1 x 7) ÷ 5 = 1.40												
INN	ER																						
7	4	AVE = (4 x 7) ÷ 7 = 4.00																					
5	1	AVE = (1 x 7) ÷ 5 = 1.40																					
Stolen Base Average (SBA)	$\frac{\text{SB}}{\text{SB+CS}}$	<table border="1" style="margin-left: 20px;"> <tr> <td>SB</td> <td>CS</td> <td></td> </tr> <tr> <td>3</td> <td>1</td> <td>AVE = 3 ÷ (3 + 1) = .750</td> </tr> <tr> <td>2</td> <td>1</td> <td>AVE = 2 ÷ (2 + 1) = .667</td> </tr> </table>	SB	CS		3	1	AVE = 3 ÷ (3 + 1) = .750	2	1	AVE = 2 ÷ (2 + 1) = .667												
SB	CS																						
3	1	AVE = 3 ÷ (3 + 1) = .750																					
2	1	AVE = 2 ÷ (2 + 1) = .667																					
Win – Loss Average (W/L)	$\frac{\text{Games Won}}{\text{Games Won+Games Lost}}$	Team Record: Win x 5 Loss x 3 AVE = 5 ÷ (5 + 3) = .625																					

The most common averages are:

8.6. Tournament Cut-offs

a. Top Batter

- For each team, find the batter with the highest PA's.
- Calculate 60% of this figure (round up to nearest whole number). Any batter in that team who has had at least this many PAs (i.e. 60% of the maximum on the team) can be included on the top batters list.

b. Top Pitcher

Sometimes the 3rd string pitcher in a top team pitches all the easy games, so can end up with the best ERA. Therefore, the top Pitcher award is **not always** determined by ERA alone.

- For each team, add up the total Batters Faced by all pitches.
- Calculate 40% of this figure (round up to nearest whole number). Any pitcher in the team who has faced at least this many batters (i.e. 40% of the team total) can be included on the pitcher list.
- The selectors at a tournament will usually select the top pitcher award from a list of the lowest approximately five Earned Run Average that qualify by facing enough batters.



Note: To find a Tournament Top Batter or Pitcher, include all games (including a final) played at the tournament.



Softball NZ Scorer's Pathway



9. Case Studies

9.1. Complicated Examples

Following are some exaggerated examples of positional changes showing some of the possibilities. It is worth spending some time to study and understand them. If you can deal confidently with such a confusing sequence you need have little worry about your ability to handle most real situations.

Vs.

TOP		BOTTOM		Inn	Inn	S	R	1	2	3	4	5	6	7
No	PLAYERS	Pos	Pos	Pos										
1	46 Tyron Bartorillo	6	6	4	6	6		1						
	5 Josh Pettett	1				3							a	
	33 Campbell Gibson	1				4		K		43		+++ 8	HP	
2	18 Nik Hayes	1	3	8	1			2						
	68 Josh Harbrow	PR				7		F7		b (3)		FC (3)	++ 78	PB (3) SB (3) c (3)
3	29 Wayne Lauulu	9												
	25 Campbell Enoka	9				1		3		a		2		1
								K		7		64		FF2

- Campbell Enoka replaced Wayne Lauulu at Right Field with 2 **OUT** in the bottom of the 1st.
- Pettett replaced Bartorillo as a batter in the 3rd, stays on to pitch. Starting pitcher Hayes went to centre field. Gibson replaced Pettett as pitcher in the 4th, so was the new batter in the 5th.
- Bartorillo re-entered in the top of the 6th to run for Gibson who was hit by the pitch, and went to 2nd.
- After 2 batters in the 6th, Hayes returned to the pitch and Bartorillo went back to shortstop.
- After Hayes batted and reached 3rd base in the 7th, he was replaced by Harbrow. As the bottom of the 7th was not required, Harbrow didn't get to take the field, so his only part in the game was as a runner (PR).
- The thick vertical lines in the first batter's line show that the **K** was Bartorillo, the **43** was Pettett the Home Run and the **HP** were Gibson, and Bartorillo did not bat again after re-entering.
- The shorter thick horizontal lines indicate that Bartorillo re-entered as a runner at first, and Harbrow replaced Hayes at 3rd base, as a runner only.

- h. The diagram below shows the point in the game that every fielding change was made, with names included for pitching changes only

VS.

TOP	BOTTOM			Inn	Inn	S	R	1	2	3	4	5	6	7					
No	PLAYERS			Pos	Pos	Pos													
1	8	Cole Evans			6			1 K		3 43			SH 8 ②						
2	7	Kallan Compain			2			2 F7		Pettett	c 78		1 SH F8						
3	6	Isaac Fletcher			3			3 K		Pettett	1 F6		2 43						
								Runs	Total	-	1	1	2	2	2	1	3	3	
								Hits	LOB	-	1	2	1	2	1	-	-	-	-
								K	BB	2	-	-	1	2	-	-	-	-	-
								A		4	23			18		76	4		
								PC		2	7	2	3	2	8	8	5	3	6
								E			6				5	4	7		



Tips

- If a team makes a lot of changes at the same time enter the shirt number, position and innings the names can be added later.
- Remember to put the vertical line for a new batter at the front of the box for the innings they enter the game not when they actually bat as in Image 1 above, Batter 3. The reason is that they may enter in one innings and then be replaced in the next so not actually bat so it would show a blank box between two solid lines.
- When a new pitcher or catcher comes into the game get into the habit of adding their name to the pitching analysis at the bottom of the scoresheet, this will help when doing your final analysis.

PITCHER	BF	W	L	INN	K	BB	R	ER	H	2B	3B	HR	WP	HP	IP	CATCHER	SB	CS	PB
Hayes																Compain			
Pettett																Van Lieshout			
Gibson																			

9.2. Batting Out of Order

Team Scorer: As a team scorer it is important to know when to inform your coach to appeal or rectify the situation.

- a. If you discover one of your players batting out of order you need to inform your coach **immediately** before the incorrect player completes their turn at bat, so you can get the correct player in the box who will assume the balls and strike count.



NOTE: If this is not discovered until after your player has completed their turn at bat you need to remain silent you have lost your chance to rectify the situation.

- b. If you think your opposition is batting out of order you need to wait for the batter in the box to complete their turn at bat and get your coach to appeal before the next pitch is delivered to the next batter.



NOTE: You should do this regardless if the incorrect batter is safe or **OUT**.

Example A

Batter 4 bats instead of batter 3.

An appeal was lodged correctly

Batter 3 is called out for failing to bat.

Because batter 4 was out the out stands

Batter 5 comes in to bat as the correct batter.

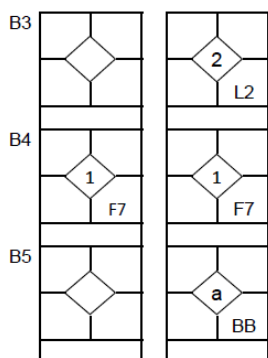

Example B

- Batter 4 bats instead of batter 3 and hits a three-base hit.
- An appeal is lodged for batting out of order Batter 3 is called out for failing to bat, Batter 4's hit is nullified (*Rule 7 Sec 2 c-d effect 2b*). Batter 4 re-enters the box as the correct batter and gets struck out.

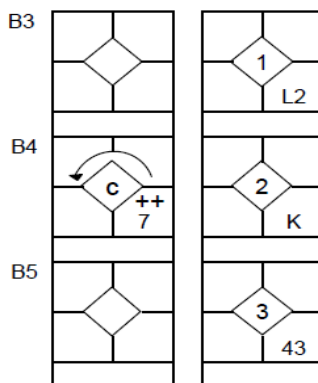

Example C

- With 2 outs batter 4 bats instead of batter 3, Batter 4 hits to shortstop who takes batter 2 at second base for the third out.
- An appeal is lodged for batting out of order, Batter 3 is called out for batting out of order Batter 4's turn at bat is nullified and he will be the first batter in the next innings (*Rule 7 Sec 2 c-d effect 2e*).

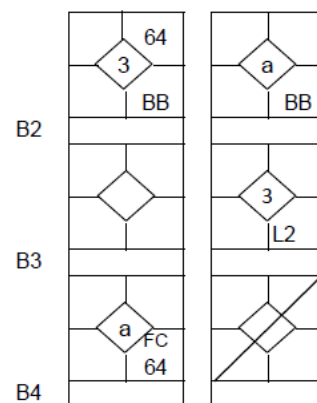

9.3. The Designated Player

The following are some examples of how a DP can be used

- a. Hayes is named as starting pitcher but at the pre-game conference the umpire is informed the DP will come into pitch. The team has temporarily gone down to 9 players. Hayes can be re-entered later in the game if required.

5	5	Joshua Pettett	DP	1	1		
	18	Nik Hayes		1	1	-	

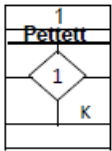

- b. Compain replaces Laulu as a runner in the top of the first, he has temporarily left the game the team has gone back to 9 players. There is no need to enter anything for the flex in the Inn/ Pos column. Simply mark the solid horizontal line at the base he has come on to. The DP may re-enter once in his place in the batting order. In this example he re-enters at the next turn At Bat so as no other player has batted before he re-entered there is no need for the vertical line for a new batter.

			Inn	Inn	S	R		
			Pos	Pos				
5	29	Wayne Laulu	DP	1	-			3
	7	Kallan Compain	2					

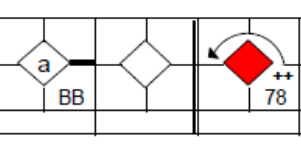

- c. Van Lieshout replaced Laulu in Top of 3 as a batter and went to catcher, Compain is now temporarily out of the game and the team is now down to 9 players. Compain re-enters the game in the bottom of the 5th, and replaces Van Lieshout to bat in the Top of the 6th, because Van Lieshout is a substitute he is now out of the game.

			Inn	Inn	S	R						
			Pos	Pos								
5	29	Wayne Laulu	DP									
	13	Zane Van Lieshout	DP	3	2		3					
	7	Kallan Compain	2	3	-		5					

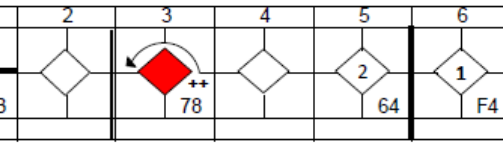

- d. Evans replaced Lauulu in the bottom 1st as a runner, Enoke replaced Evans in the Top of the 3rd as a batter, **because there is no space to record his name under Evans, we use the last line of the batter above.** Evans has now left the game. In the Top of 5th Van Lieshout bats in place of Enoke, Enoke has now left the game and because Van Lieshout is the flex know playing offence for the DP Wayne Lauulu the original DP is now considered to have left the game but may still re-enter the game at a later stage in his batting position.

20	Thomas Enoke	DP																		
29	Wayne Lauulu	DP	5	-																
3	Joel Evans	PR																		
7	Kallan Compain	2																		
13	Zane Van Lieshout	2																		



TIPS

- The DP and Flex **can play** defence at the same time but both **cannot** bat at the same time.
- The DP can play defence for any player in the starting nine or their substitutes, if this occurs that player then becomes the **OPO** (Offensive player only).
- The DP **cannot** play Defence only and the Flex **cannot** play Offence only (Rule 3.2.4 and 3.2.5).

9.4. Reach Base

These examples show scenarios that people have difficulty with when recording Reach Base, and the use of the OE and FC Column, Including SHE, SHFC, FC (No OUT), FCE.

Example 1:

Innings 1 Batter 2 reaches first base on a fielder’s choice where a proceeding runner is taken out therefore this **is not a reach (RCH)** but it is a reach at bat (RAB).

	1	2	3	4	5	PA	AB	BB	SH	CO	HP	H	2B	3B	HR	RBI	K	SB	CS	OE	FC	R	RCH	RAB
1	54 3 6		1 43		8 +++	3	3					1			1	1						1	2	3
2	a FC 54		1 K		a 78	3	3					1				1							1	3

Example 2:

- **Innings 1 Batter 2** reaches first base on an error by third base on a Sacrifice Bunt advancing the runner to second. In the reach this is recorded as an **OE as well as a Reach (RCH) and a Reach at Bat (RAB)**
- **Innings 2 Batter 2** reaches first base on a Sacrifice Bunt where the fielder has chosen to try for the runner going to two but the runner beats the throw. As there is no error the batter still gets the Sacrifice and it becomes a SHFC. **In the reach this is recorded as an OE as well as a RCH and a RAB.** It doesn't get recorded in the FC column. In this case the RAB does not equal the PA - SH.

		1	2	3	4	5	PA	AB	BB	SH	CO	H	2B	3B	HR	RB	K	BB	CS	OE	FC	R	RCH	RAB
1	b	SH (2) BB		b 56 g		b (2) 8	3	2	1			2											3	3
2	a	SH E5		a SH FC56		a 78	3	1		2		1				1				2			3	3

Example 3:

Innings 1 Batter 2 reaches first safely on a fielder's choice (FC) as the fielder tries to get the proceeding runner but the runner beats the throw. This is the only time we use the FC column for the Reach. **This gets recorded as a FC, it is a Reach (RCH) and a Reach at Bat (RAB).**

		1	2	3	4	5	PA	AB	BB	SH	CO	H	2B	3B	HR	RB	K	BB	CS	OE	FC	R	RCH	RAB
1	b	54 BB		1 K		b (2) 8	3	2	1			1					1						2	3
2	a	FC 54		2 K		a 78	3	3				1				1					1		2	3

Example 4:

Innings 1 Batter 2 is **OUT** on a Sacrifice Bunt advancing the runner safely. **Therefore, it is not a Reach (RCH) or a Reach at Bat (RAB).** This is the only time the RAB equals the Plate Appearance (PA) minus Sacrifice Hits (SH).

		1	2	3	4	5	PA	AB	BB	SH	CO	H	2B	3B	HR	RB	K	BB	CS	OE	FC	R	RCH	RAB
1	b	SH (2) BB		1 K		b (2) 8	3	2	1			1					1						2	3
2	1	SH 54		2 K		a 78	3	2	1			1				1							1	2

Example 5:

Innings 1 Batter 2 reaches first base on a FC because the fielders attempted to take the proceeding runner but they make an error, because of this it is counted as a reach for the batter **This gets recorded as an OE as well as a RCH and a RAB.**

	1	2	3	4	5	PA	AB	BB	SH	CO	H	2B	3B	HR	RB	K	SB	CS	OE	FC	R	RCH	RAB	
1	b 5E4 BB		1 K		b (2) 8	3	2	1			1												2	3
2	a FC 54		2 K		a 78	3	3				1								1				2	3



TIP: Checking:

To check you have recorded your reach correctly uses the following:

RAB (Reach at Bat) is

PA less any SH Outs or AB + SHE + SHFC + HP + CO

RCH (Reach) is

BB + HP + CO + H + OE + FC.

RAB and RCH Practical Example

Using the example below, you can determine the following:

PA	AB	BB	SH	CO	H	2B	3B	HR	RB	K	SB	CS	OE	FC	R	RCH	RAB
30	23	4	3	/	11			1	1	8			3	1	1	19	29

RAB is

PA - SH Outs or AB + BB + SHE + SHFC + HP + CO

30 PA - 1 SH Out = **29** or 23 AB + 4 BB + 1 SHE + 1 SHFC = **29**

RCH is

BB + HP + CO + H + OE + FC

4 BB + 11 H + 3 OE + 1 FC = **19**

9.5. Reconstruction Practice examples

Practice on these examples. The number of earned runs is at the bottom of each set.

Original		Reconstruction	Original		Reconstruction	Original		Reconstruction
1			1			1		
2			2			2		
3			3			3		
4			4			4		
5			5			5		
6			6			6		
7			7			7		
8			8			8		
9			9			9		
2 Earned Runs			1 Earned Run			1 Earned Run		

9.6. Statistical Averages: Batting, Reach and Pressure

a. Batting Average (BA)

		PA	AB	BB	SH	CO	H	2B	3B	HR	RBI	K
46	Tyron Bartorillo	4	3			1	1			1	1	1

Batting Average 1hit ⇌ 3 At bats = .333

b. Reach Base Average (OBP)

		PA	AB	BB	SH	CO	H	2B	3B	HR	RBI	K	SB	CS	OE	FC	R	RCH	RAB
46	Tyron Bartorillo	3	2	1		1												2	3

Reach Average - 1H + 1 BB ⇌ 2 AB + 1 BB = 2 RCH ⇌ 3 RAB AVE .667

		PA	AB	BB	SH	CO	H	2B	3B	HR	RBI	K	SB	CS	OE	FC	R	RCH	RAB
46	Tyron Bartorillo	3	1	1	1	1	1											2	2

SH is an OUT

Reach Average - 1H + 1 BB ⇌ 1 AB + 1 BB = 2 RCH ⇌ 2 RAB AVE 1.000

		PA	AB	BB	SH	CO	H	2B	3B	HR	RBI	K	SB	CS	OE	FC	R	RCH	RAB
46	Tyron Bartorillo	4	2		2	1	1								2	1		4	4

SH - 1 SHE, 1 SHFC (Remember for Reach this is entered as an OE not FC)

1 AB is a FC with no OUT and the preceding runner advanced safely

Reach Average - 1H + 2 OE + 1 FC ⇌ 2 AB + 2 SH = 4 RCH ⇌ 4 RAB - AVE 1.000

c. **Pressure Batting Average**

Example 1

Batter is under pressure for 3 AB but only 2 are counted as PAB because the BB does not result in an RBI. Even though the SH is not recorded as a hit, for Pressure he is given a hit for to enable an average to be calculated. His pressure would read:

$$2 \text{ HITS} \div 2 \text{ AB} = \text{AVE } 1.000$$

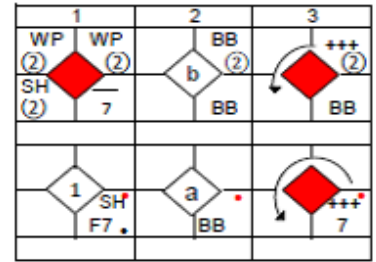

Example 2

Batter has 3 AB but only 2 are under pressure, as the runner scores before his turn is completed on second occasion. The first FC is only recorded as a PAB as the runner did not advance safely. The other is recorded as an AB and a H as it is an RBI. His Pressure would read:

$$1 \text{ Hit} \div 2 \text{ AB} = \text{AVE } .500$$

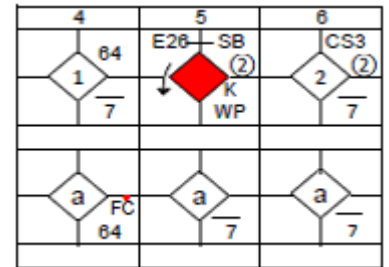

Example 3

Batter has 3 AB but only 2 are under pressure, as the runner scores before his turn is completed on second occasion. The first FC is only recorded as a PAB as the runner did not advance safely. The other is recorded as an AB and a H as it is an RBI. His Pressure would read:

$$1 \text{ Hit} \div 2 \text{ AB} = \text{AVE } .500$$

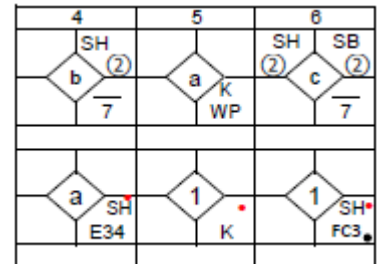

10. Index

A

Analysis	
Blood Bin	38
Catching.....	43
Cross Checks.....	51
Fast Pitch	51
Fielding Summary.....	42
Innings Pitched	44
Pitching.....	43
Pressure batting	41
Reach Base	41
Runs Batted In	40
Splitting batters.....	41
Tie Breaker	51
Winning and Losing Pitcher.....	44
WP, PB and IP.....	44
Avoiding Tag.....	22

B

Ball 4 on WP or PB.....	18
Baserunning	20
Avoiding Tag	22
Caught Stealing	20
Fielders Choice	20
Forced out	22
Hit by batted ball.....	22
Illegal Running.....	20
Left Base Early	20
Missed Base.....	21
Out Returning to Base After Catch.....	14
Passed Ball.....	20
Runners Interference	21
Stolen Base.....	20
Tagged.....	22
Wild Pitch	20
Batter Called Out.....	15
Battery Errors	
Illegal Pitch	19
Wild Pitch/Passed Ball.....	19
Batting	
Batter Called Out.....	15
Illegal Substitute.....	15
Missed Turn at Bat	15
Out of Order	15
Out Of Order	61
Blood Bin.....	37
Bunt.....	13

C

Catching	
Catcher's Error	45
Catcher's Obstruction	45
Catchers Error	18
Passed Ball	19
Caught Ball	
Carried Dead	14
Drive.....	15
Fly Ball	14
Infield Fly.....	14
Out Returning to Base After Catch.....	14
Change Indicator Lines	
Baserunning	35
Batting.....	33
Fielding.....	35
Pitching	35
Re-entry	35

D

Designated Player	36, 62
Designated Runner	37
Double and Triple Plays	29
Double Steal.....	31
Drive.....	15

E

Earned Runs	
Definition	44
Hints.....	45
Reconstruction.....	44
Showing.....	45
Error	31
Advance-Errors.....	27
Assists.....	28
Definition	23
Extent.....	26
Foul Fly	30
More Than One.....	26
Out Error	27
Reverse Error	25
Sacrifice Fly	30
Scoring An Error	24

F

Fast Pitch.....	32
Fielder's Choice.....	20, 28, 31
On Batter.....	28

On Runner	29
Flex Player	36
Force Out	22
Foul Fly	30

G

Game	
Analysis.....	5
Start Time.....	6
Summary	6, 49

H

Hit by Batted Ball	22
Hit by Pitch	19
Hits	
Automatic.....	12
Extra Base Advance	11
Hit Location	11
Length	12
Runners Advance.....	11
Safe Hits	10
Slap.....	12

I

Illegal Batting	17
Illegal Pitch	19
Illegal Running.....	20
Illegal Substitute	15
Infield Fly.....	14
Innings	
Closing Off	6
Fielding.....	7
Overflow.....	8
Totals.....	7
Intentional Walk.....	18
Interference	23
Batters.....	23
Team.....	23

M

Missed Base	21
Missed Turn at Bat	15
Multi-Symbol Plays.....	30

O

Obstruction	23
Catcher's Obstruction	23
Fielder's Obstruction.....	23
Offensive Player Only	36

P

Passed Ball	19
Pitching	
Earned Runs	44
Illegal Pitch.....	19
Wild Pitch	19
Position Change	36
Protests.....	54
Proving the Box Score	50

R

Reach Base.....	63
Re-entry	33, 35
Runs Scored	54

S

Sacrifice.....	13
Bunt.....	14, 31
Fly13	
Scoresheet	
Overflow	8
Parts	3
Team Lineups	4
Top/Bottom	4
Scoring	
Duties.....	53
Judgement	23
Second Phase Play	
On Batter.....	29
On Runner	29
Statistician.....	55
Statistics	
Batting Average.....	67
Common averages	56
Equations	56
Expressing averages	56
Preparation	55
Pressure Batting Average.....	68
Reach Base Average	67
Requirements.....	55
Top batter	57
Top pitcher.....	57
Stolen Base	30
Strike Out	17
Dropped Third Strike.....	17, 18
Third Strike Bunted Foul	17
Third Strike Not Swung At.....	17
Third strike Swung At.....	17
Substitute.....	33
Symbols.....	9
Balls and Strikes Count.....	10
Batting and Running.....	39

T

Tag.....	22
Team Sheets.....	5
The Box	6
Tie Breaker	32, 45, 51
Tied Team Formula	53
Tied Team Score.....	52

U

Umpires Decisions	54
-------------------------	----

W

Walk	18
Intentional.....	18
Wild Pitch.....	19